

Installation Instructions

PRO-FLO[®]2
ELECTRONIC
FUEL INJECTION

Pro-Flo2 System #35000
Shown Here

**Multi-Point Electronic
Fuel Injection**



TABLE OF CONTENTS

Part #35500 and #35510

Introduction.....	1
Components.....	2
Preliminaries.....	3
Fuel System.....	6
Induction System.....	10
Sensors.....	13
O2 Sensor Installation.....	14
Sensor Installation.....	15
Main System Harness.....	16
Ignition System.....	21
Software Installation.....	26
Calibration Selection.....	27
Other Applications.....	28
System Start-Up.....	28
Electronic Engine Management.....	31
Pro-Flo Quick Tuning Guide.....	32
Optional PC Tuning.....	33
Calibration Module Flowchart.....	34
Parts and Part Numbers.....	35
Service & Warranty.....	37

INTRODUCTION

Thank you for selecting the Edelbrock Pro-Flo Fuel Injection System. This Multi-Point Fuel Injection System has been designed for 454 c.i.d. big-block Chevrolet engines, and is designed to provide excellent performance, fuel economy, and maintenance-free operation. Installation of the Edelbrock/ Pro-Flo Fuel Injection System involves modifications to the fuel system, ignition system, induction system, and possibly the valve train. Although there are steps that must take place before others, the modifications do not necessarily have to be performed in a particular order. Each modification is described in a separate section in this manual. Please study these instructions carefully before beginning installation of any part of the Pro-Flo system.

**If you have any questions, do not hesitate to call our
EFI Technical Hotline at (800) 416-8628, 7am-5pm PST, Monday-Friday**

(In order to properly relay your call, please press 1 at the prompt to select Automotive Products, followed by 3 to select EFI-Electronics then 1 again for Multi-Point EFI.)

Our EFI Technical Support staff can also be reached via email at: EFItch@Edelbrock.com



PRIMARY KIT COMPONENTS

- Electronic Control Unit/System ECU
- Calibration Module
- Distributor conversion kit
- Fuel injectors
- ECU power relay/Fuel pump relay
- Manifold Absolute Pressure (MAP) Sensor
- Manifold Air Temperature (MAT) Sensor
- Coolant Temperature Sensor (CTS)
- Throttle Position Sensor (TPS), integrated with air valve
- Oxygen (O₂) sensor
- USB/Serial Converter
- Software CD
- Fuel filter
- Fuel rail assembly
- Fuel pressure regulator
- High pressure fuel pump
- Intake manifold
- Four barrel air valve
- Idle Air Control (IAC) solenoid, integrated with air valve
- Main system harness
- Fuel pump harness
- Installation package
- Ignition Harness

Many Pro-Flo components, including the Manifold Absolute Pressure sensor, fuel pressure regulator, Coolant Temperature sensor, and the fuel filter are standard OEM pieces. In the event that one of these parts needs to be replaced, you are likely to find a replacement at your local parts supplier, in addition to your local Edelbrock dealer or directly from Edelbrock. For a list of part numbers, refer to the **PART NUMBERS** section at the back of this manual.

TOOLS AND EQUIPMENT

Use the following checklist for items needed.

- Box and open end wrenches
- Socket set
- Distributor wrench
- Pliers (channel locks and hose clamp)
- Screwdrivers (regular and Phillips)
- Torque wrench
- Hammer
- Gasket scraper or putty knife
- Timing light
- Vacuum gauge
- Rags
- Water bucket
- Drill and bits
- Hole saw (1 1/4-inch or 1 3/4-inch)
- Tubing wrenches
- Tubing cutter

HARDWARE AND PARTS RECOMMENDED

Use the following checklist for items needed.

- Intake gasket - Edelbrock #7203, OEM, or equivalent
- Pipe plugs, if needed
- 5/16-inch steel tubing (approximate equal length to fuel pickup line in tank)
- Edelbrock Gasgacinch #9300
- Loctite 598 OEM High Temperature Silicone Gasket (O₂ Sensor Compatible)
- Radiator coolant
- Wiring diagram for your vehicle
- Teflon tape or liquid Teflon thread sealer
- Manifold bolt kit #8564
- Throttle, Cruise Control & Trans. Kick-Down Mounting Bracket #8031 (If Necessary see general catalog)
- 195° Thermostat
- Resistor type spark plugs (Use correct heat range for your particular application)
- Set of low-resistance spark plug wires with high EMI suppression (DO NOT use solid core spark plug wires)
- Dynojet wideband commander (Optional, not included)
- DB9 Serial cable (Optional, not included)

PRELIMINARY CHECKLIST

1. CAREFULLY STUDY AND UNDERSTAND ALL INSTRUCTIONS, BEFORE BEGINNING THIS INSTALLATION.

NOTE: This installation can be accomplished using common tools and procedures. However, you should have a basic knowledge of automotive repair and modification and be familiar with and comfortable working on your vehicle. If you do not feel comfortable working on your vehicle, it is recommended to have the installation completed by a professional mechanic.

2. Examine the Pro-Flo system for possible shipping damage. If damaged, contact your dealer immediately.

3. The 35500 & 35510 kits are designed for use with a standard Big Block Chevy V8 firing order.

4. Check all threaded manifold holes.

5. Check all internal manifold passages with a light and wire, making sure they are clean and unobstructed.

6. Check automatic transmission shift points before removal of your stock manifold and adjust linkage after Edelbrock manifold installation for same shift points (if needed).

NOTE: We recommend that you refer to this checklist again after installation to be sure that you have completed all steps.

DETERMINING HOOD CLEARANCE

NOTE: Check hood clearance before removing stock manifold.

1. Use modeling clay or putty to make five small cones, two or three inches high.
2. Position cones on air cleaner at front, rear, each side, and on center stud.
3. Close hood to locked position and re-open.
4. The height of the cones indicate the amount of clearance between the hood and the air cleaner. Record these measurements.

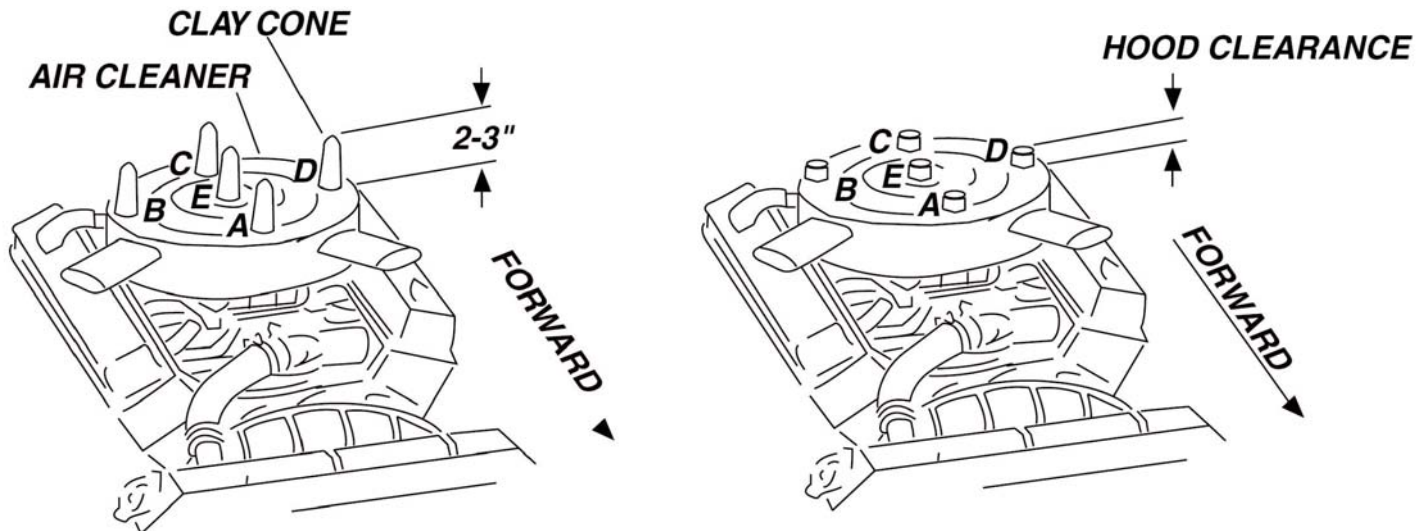

MANIFOLD & CARBURETOR HEIGHT VS. PRO-FLO HEIGHT

1. Remove air cleaner.
2. Lay a straightedge (such as a yardstick) across the top of the carburetor from front to back.
3. Measure from block and manifold end seal surfaces to straightedge.
4. Record these measurements (height A and height B).
5. Add height A and height B and divide by two to get the average height.
6. The Pro-Flo manifold and air valve measures 7.55" at the (A) and 9.10" at the rear (B).
9. Compare the two measurements. If the Pro-Flo unit is taller, subtract this amount from the hood clearance figure to determine new hood clearance.

CAUTION: You must maintain at least 1/2-inch clearance between the hood and air cleaner because of engine torque. If you have insufficient clearance, a low profile air cleaner may solve the problem.

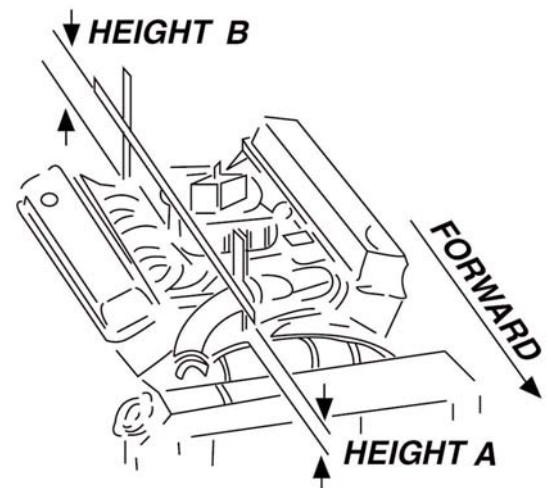

EMISSION CONTROLS

The Edelbrock Pro-Flo system will not accept stock emissions control systems. Check local laws for requirements before installing the Pro-Flo system. Not legal on pollution-controlled motor vehicles.

FUEL REQUIREMENTS

Because the Pro-Flo system uses an Oxygen sensor, it is recommended that you use unleaded fuel only. Leaded fuels will shorten the life of the O₂ sensor.

AUTOMATIC TRANSMISSION CHECK

For best performance, economy, and emissions, the shift point must be checked before and after the manifold change.

NOTE: This check should be performed **ONLY** at a sanctioned drag strip or test track.

With the shifter in Drive, accelerate to wide open throttle from a standing start. Hold in this position, noting speedometer MPH when the transmission makes the first 1-2 shift. After the Pro-Flo system has been installed, make the same test, again noting MPH of this first shift.

If adjustment is necessary, we recommend use of the Edelbrock Throttle, Cruise Control, & Transmission Kick-Down Mounting Bracket #8031. The Turbo 350 and Turbo 200 feature a window to accommodate user adjustment of shift points at WOT.

The transmissions in certain vehicles require precise adjustments. We recommend that you consult a reputable transmission shop for final adjustments once the Pro-Flo system has been installed. Incorrect shift points can result in transmission damage.

ENGINE CLEANING

Edelbrock recommends that the Pro-Flo system be installed on a clean engine in order to prevent dirt from falling into the engine lifter valley or intake ports.

1. Cover ignition. Use engine degreaser and a brush to thoroughly clean the manifold and the area between the manifold and valve covers.
2. Rinse with water and blow dry.

EXHAUST MANIFOLD HEAT RISER VALVE

If your vehicle is equipped with an exhaust manifold heat riser valve (typically located on the passenger side of the vehicle below the exhaust manifold), remove the valve for proper operation. If applicable, any air injection tubes must be removed and holes in the exhaust manifold plugged for proper operation.

HEADERS

For best performance, headers are recommended. For this application, header primary tube diameter should be 1-3/4 inch, approximately 31 inches long and terminating into a 3 inch collector. The remainder of the exhaust system should consist of dual exhaust and tail pipes, at least 2-1/4 inches in diameter with low back pressure mufflers.

COOLING SYSTEM

The minimum requirements for the thermostat are 180° but the ideal thermostat is 195°. When the vehicle is at 175 or below, system will stay in warm-up enrichment mode and not perform properly.

FUEL SYSTEM

Because your Edelbrock Pro-Flo system controls fuel delivery very differently than a carburetor, some conversions to your fuel system are necessary. Pro-Flo electronic fuel injection requires high and constant fuel volume and fuel pressure. For this reason, a good primary fuel line is critical. The Pro-Flo system includes a 3/8-inch high pressure fuel line which must be used as the primary fuel line. The fuel that bypasses the injectors must be returned to the fuel tank via a return fuel line. If your vehicle is already equipped with a fuel pump bypass line, this line can be used as the return fuel line. If not, the original primary line may be used as the return line. If desired, an 8 foot length of 5/16 ID rubber hose is supplied for use as the return line.

Many late-model cars are equipped with an additional fuel line which runs to a charcoal canister mounted on the driver side of the vehicle. This line **MUST** be re-installed after the fuel system conversion and **MUST NOT** be used as the return fuel line.

FUEL PUMP AND FILTER

The Pro-Flo system uses a single Edelbrock high-pressure electric fuel pump which is capable of pumping 50 psi. The pump relay will shut down the pump if it does not receive an engine-run signal from the ECU, as in the case of a stall. This safety precaution is necessary when using a high-pressure fuel line. The provided fuel filter should be mounted between the engine compartment and the fuel pump to allow fuel to be pushed through the filter rather than drawn through. Electrical connectors should face the front of vehicle. Make sure the fuel pump is mounted at or below the bottom of your fuel tank. If the pump is mounted above this point, fuel pump failure will occur.

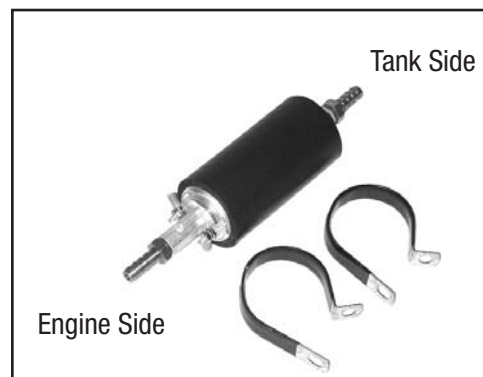

FUEL PRESSURE REGULATOR

Fuel pressure is as important as fuel volume, particularly in fuel injection. The Pro-Flo fuel pressure regulator maintains a constant pressure at the injectors with a spring loaded by-pass to the return fuel line. Manifold Absolute Pressure references the regulator diaphragm to maintain constant pressure across all 8 injectors, regardless of fluctuating manifold pressure (vacuum) level. The fuel that is not injected is returned to the fuel tank via the return fuel line.



RETURN FUEL LINE

Due to the high fuel pressure used by the Pro-Flo system, **the supplied 3/8-inch high pressure fuel line MUST be used as the primary fuel line**, and a bypass fuel return line must be installed. There are three options for installing a bypass return line.

1. Use the 5/16 rubber fuel line provided with the system as the fuel return line.
2. Use the vehicle's existing primary line as the fuel return line with modification to the pick up as described below.
3. Use the vehicle's existing return line (if so equipped) as the fuel return line. This option applies only to vehicles previously equipped with fuel injection. If the vehicle is not already equipped with a return line, some fuel tank modifications are required for routing the return line through the sending unit plate back into the tank. The first two methods listed below require some welding and should be done by a professional radiator or fuel system repair shop.

RUBBER RETURN LINE METHOD

Drill a 5/16-inch hole in the sending unit plate adjacent to where the main line enters the tank. This will be the hole for your return line. Insert a short length of 5/16-inch hard line (available at most radiator shops) into the hole and weld it to the sending unit plate. The hard line should extend through the hole 1 to 2 inches on each side of the plate. Connect a length (at least 4 inches) of 5/16-inch rubber return line hose to the hard line that will extend into the tank. Connect the rubber line to the fuel pickup line using tie wraps.

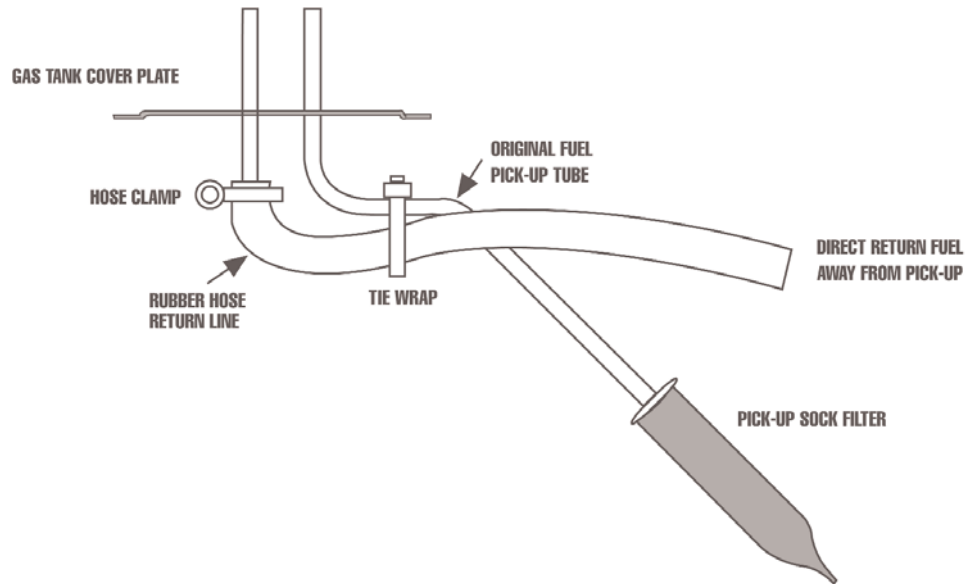

RUBBER HOSE METHOD

BULKHEAD FITTING METHOD

Drill a 9/16-inch hole in the sending unit plate adjacent to where the main line enters the tank. This will be the hole for your return line. Insert a #6 AN bulkhead fitting (available at most radiator shops) into the hole, the narrow end of the fitting on the inside of the plate. Apply a rubber washer or RTV sealant and fasten the fitting to the plate with the nut. Connect a length (at least 4 inches) of flexible return line (rubber or braided hose) to the fitting end. Connect the return line to the fuel pickup line using tie wraps.

NOTE: THIS METHOD REQUIRES NO WELDING OF THE FUEL SYSTEM.



NOTE: Whichever method you use to install the return fuel line, be careful to keep the end of the line away from the fuel pickup, as shown. Otherwise, aerated return fuel can be drawn into the pickup.

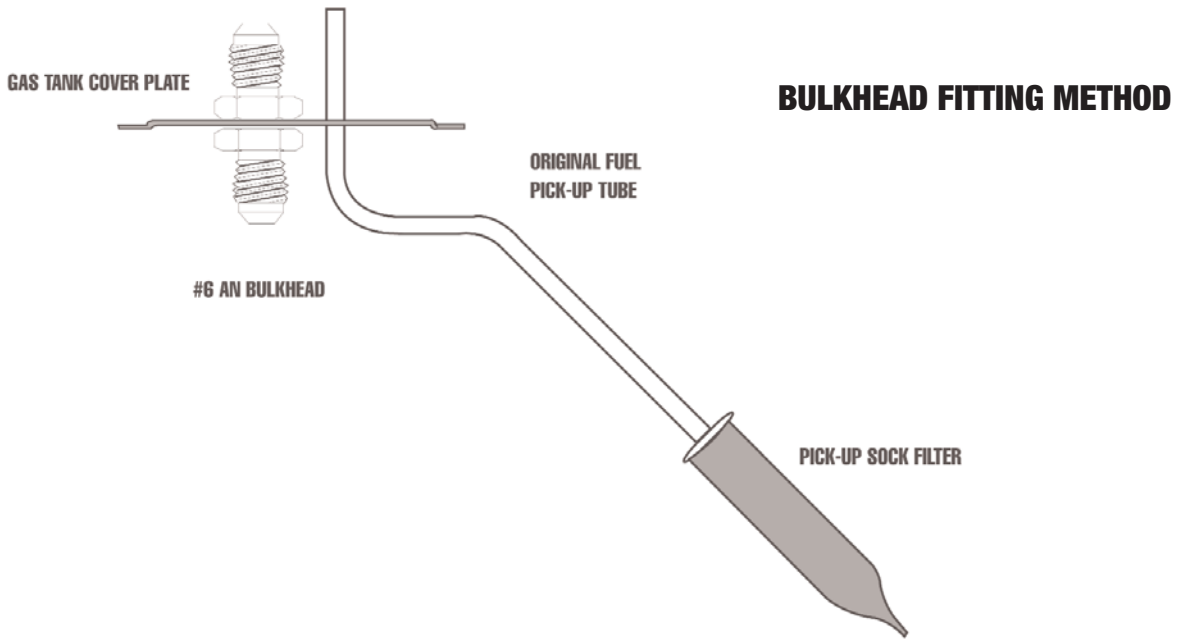

HARD RETURN LINE METHOD

Drill a 5/16-inch hole in the sending unit plate adjacent to where the main line enters the tank. This will be the hole for your return line. Insert a length of 5/16-inch hard line (available at most radiator shops) into the hole and weld it to the sending unit plate. The hard line should extend through the hole 1 to 2 inches on the outside of the plate. On the inside of the plate, the hard line should follow the contours of the fuel pickup line. Bend the end of the return line away from the sock on the end of the fuel pickup line. Solder or weld the return hard line to the fuel pickup line.

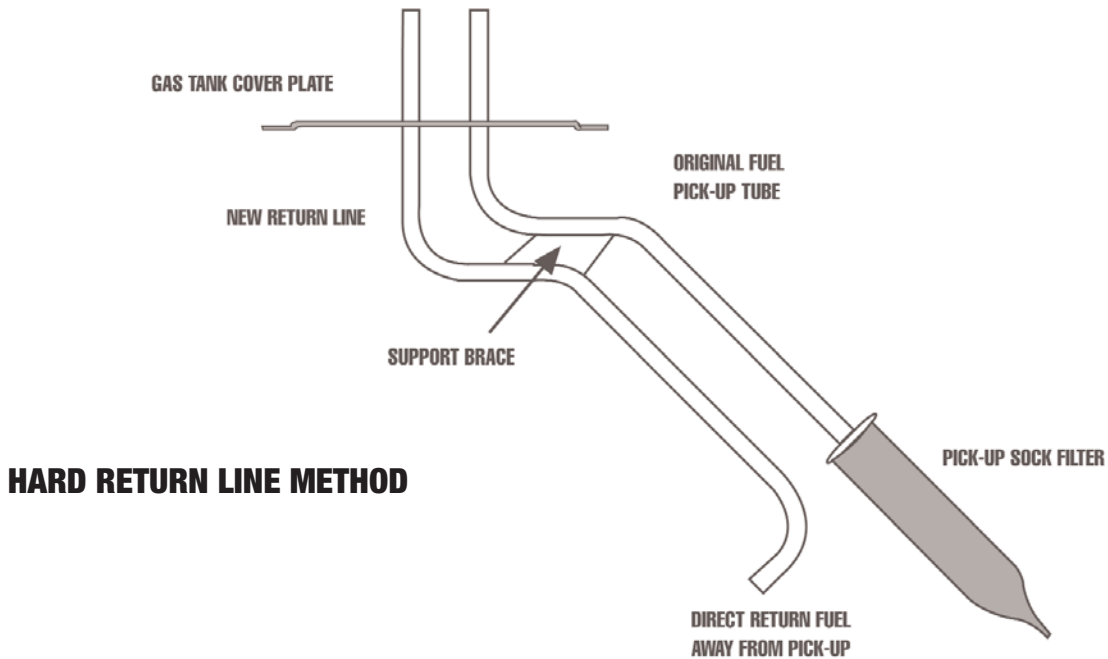

NOTE: ALL WELDING AND SOLDERING OF THE FUEL SYSTEM MUST BE PERFORMED BY A PROFESSIONAL RADIATOR AND/OR FUEL SYSTEM REPAIR SHOP.

FUEL SYSTEM INSTALLATION

1. Drain the fuel tank.
2. Remove all fuel lines from the tank and from the carburetor.
3. Remove the fuel tank.

NOTE: While the fuel tank is removed from the car, it is recommended that it be professionally cleaned in order to remove any rust or dirt that may have accumulated inside and which could damage the injectors.

4. Remove the sending unit from the fuel tank. Refer to the RETURN FUEL LINE methods above for installing the bypass fuel return line.



5. Install the provided 3/8-inch primary fuel line directly above the original line, which may now serve as a return line. Use large radius bends. Avoid the exhaust pipe and any sharp edges.

NOTE: The 3/8-inch high pressure fuel line supplied with the Pro-Flo system must be used as the primary fuel line.

6. If you do not use the original fuel as the return line, route the return line directly alongside the provided 3/8-inch primary fuel line.
7. Mount the fuel pump between the tank and the fuel filter as low and as close to the fuel tank as possible. The pump is directional. Electrical connectors should face the front of vehicle. The fuel pump needs to be at or **below** the bottom of the fuel tank.



8. Mount the fuel filter between the fuel pump and the engine.
9. Re-install the modified sending unit plate to the clean fuel tank.
10. Reinstall the fuel tank.

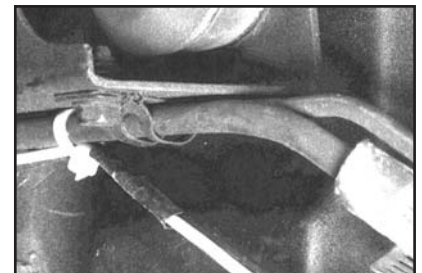

11. Attach the primary line and return line to the sending unit plate on the tank.
12. Re-attach all other fuel lines at the tank (vapor purge lines, etc., if so equipped).
13. Secure the primary and return fuel lines with the provided tie-wraps, or with Adel clamps if available.
14. Re-attach all fuel lines to the induction system once it has been installed.
15. Use the 10-foot wiring harness to connect the fuel pump to the Main System Harness. Route the harness away from the exhaust pipe and any sharp edges. This harness may be cut to length. Replacement terminals are provided with the Pro-Flo system. Cover the connection to the positive terminal with the sleeve and tie wrap provided. Refer to the MAIN SYSTEM HARNESS section of this manual for details.



16. Before starting the engine, turn the ignition key to the ON position 4 or 5 times to prime the electric fuel pump, fuel lines, and fuel rails. You should hear the pump run for approximately 2 seconds each time. Check the entire fuel system for leaks. Refer to the SYSTEM START-UP section of this manual for details.

INDUCTION SYSTEM

The Edelbrock Pro-Flo system delivers fuel and air to the engine via the induction system consisting primarily of a manifold, 4-barrel air valve, fuel rails, and fuel injectors. The induction system is fully assembled, tested, seal checked, and flowed at the factory and is as easy to install as a manifold. DO NOT DISASSEMBLE any of these components during installation.

FUEL RAILS

The extruded aluminum rail assembly routes the high pressure fuel to the injectors. Aluminum rails have an advantage over soft rails both in terms of style and safety.

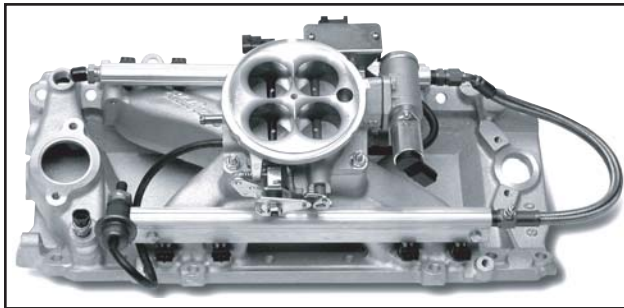

INTAKE MANIFOLD

The new Edelbrock manifold used with the Pro-Flo system is very similar to the successful Victor Jr. high-performance single-plane manifold, but has been designed specifically for electronic fuel injection applications.

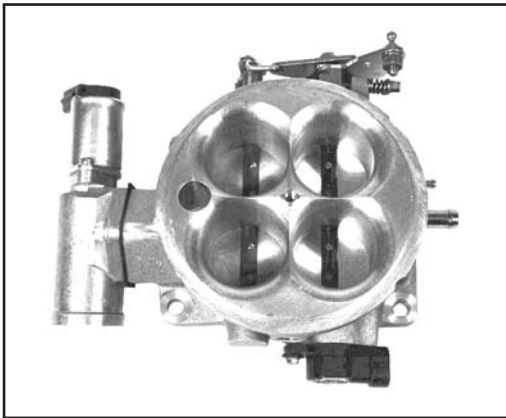

4-BARREL AIR VALVE

The Pro-Flo system uses a progressive linkage valve body with four throttle blades arranged in a conventional 4-barrel pattern, with staged secondaries. The air valve can flow up to 1000 cfm at 1.5" of mercury when wide open.

FUEL INJECTORS

The Pro-Flo #35500 & 35510 systems use high impedance pintle-type fuel injectors. The injectors used with #3550 are capable of flowing 44 lbs./hr. at 50 psi. The #35510 uses 29 lbs./hr. injectors. The injectors mount directly onto the manifold, one at each port, for fuel delivery that is precisely controlled and instantaneously injected.



PRE-INSTALLATION

Before installing the induction system, take the following steps to ensure successful installation and performance

1. Check all components thoroughly for damage.
2. Make sure all throttle linkages open entirely and close freely.
3. Make sure all fuel inlet and vacuum ports are free from packing material.
4. Check the installation kit for proper parts.

REMOVING THE STOCK CARBURETOR AND MANIFOLD

1. Disconnect battery.
2. For ease of installation, keep all parts in order.
CAUTION: Do not remove manifold if engine is hot.
3. Drain radiator coolant (radiator drain plug is typically located on lower right facing engine).
4. Remove gas cap to relieve pressure. Disconnect fuel line and plug. Replace gas cap.
5. Disconnect all linkage from carburetor such as throttle, throttle springs, transmission, cruise control and automatic choke.
6. Tag and remove coil wires and sensor wires.
7. Remove previously marked vacuum lines.
8. Remove radiator hose, thermostat housing and thermostat, if mounted on manifold.
9. Remove all brackets from the manifold.
10. Loosen or remove valve cover bolts for manifold removal and replacement. It may be necessary to replace valve cover gaskets, if broken, to prevent oil leakage.

PORT SURFACE CLEANING

When cleaning old gaskets from head surfaces, lay rags in the lifter valley and stuff paper into the ports, to prevent pieces of the old gasket from falling into ports and combustion chambers. When clean, remove paper, making sure that all particles fall on the rags in the lifter valley. Remove rags, and wipe surfaces clean with rags soaked in lacquer thinner in order to remove oil or grease. NOTE: This procedure is necessary to ensure proper sealing.

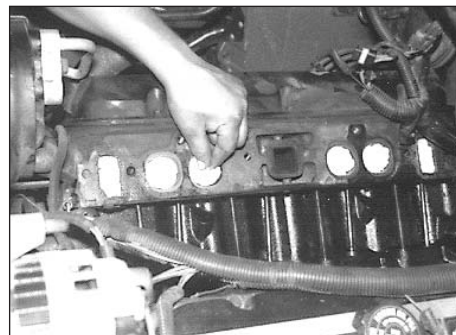

INSTALLING FITTINGS, PIPE PLUGS, AND STUDS

Do not over-tighten or cross-thread fittings, pipe plugs, studs, or bolts in your aluminum manifold. Damage to threads or a cracked mounting boss may result unless caution is used when installing accessories.

Use high quality pipe thread sealant on all threads. Install fittings from your stock manifold.

GASKET SURFACE PREPARATION

CAUTION: Replace all gaskets as recommended. Do not use race-type non-embossed gaskets for street applications. Due to material deterioration under street driving conditions, internal vacuum and oil leaks may occur. We recommend Edelbrock gaskets #7203 or equivalent. Do not use Fel-Pro Permatorque Blue gaskets, which are designed for use on stock cast iron intake manifolds only.

1. Check gaskets on head surface and manifold to make sure they are correct. Embossed side faces up (**NOTE:** In some cases, there may be a different right and left side gasket. Make sure both are placed correctly.).
2. Coat head surface and both sides of gaskets with Edelbrock Gasgacinch #9300.
3. Apply Loctite 598 OEM High Temperature Silicone Gasket around water passages on head surface.
4. Gaskets and surface will become tacky to the touch within a few minutes. Carefully place gaskets on head surface, aligning ports and bolt holes.
5. Edelbrock recommends the use of Loctite 598 OEM High Temperature Silicone Gasket instead of end seal gaskets. Apply a 1/4-inch thick bead of sealant across each end seal surface, overlapping the intake gasket at the four corners (**NOTE:** Use the recommended silicon sealer. Others may damage the O2 sensor. This method eliminates end seal slippage and deterioration. For ease of installation, we recommend using Edelbrock Manifold Bolt and Washer Kit #8564.).
6. Apply Edelbrock Gasgacinch #9300 to port surface of the manifold and to the head surfaces to ensure a good seal.
7. Apply RTV gasket sealer around water passages on the manifold.
8. Surfaces will become tacky to the touch within a few minutes.

INDUCTION SYSTEM INSTALLATION

1. Carefully position manifold and air valve on engine, centering bolt holes with the bolt holes in the head.
2. Apply thread sealer or Teflon tape to bolt threads where exposed to water or oil.
3. Hand tighten all bolts.
4. Torque all manifold bolts to 25 ft/lbs. Torque in the sequence illustrated.
5. Re-connect throttle linkage and springs, transmission, cruise control, and fuel lines. Check all linkage for smooth throttle operation from idle to Wide Open Throttle.

Note: Do not install with a throttle rod, use a cable actuated throttle.

6. Re-tighten the valve cover bolts.

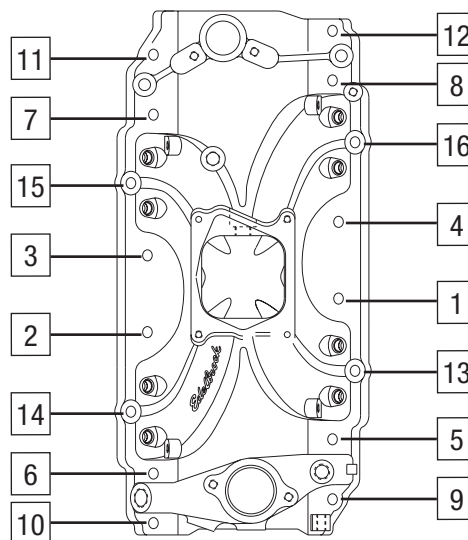

Kit #35500 & #35510

SENSORS

The Edelbrock Pro-Flo system interprets overall engine operating conditions and fuel/spark requirements based on readings from sensors that measure specific engine conditions. These sensors, with the exception of the O₂, are designed as an integral part of the induction system and require no installation. The O₂ sensor must be installed on the exhaust pipe near the engine with a welded fitting.

The Pro-Flo system includes five sensors:

- 1) Manifold Absolute Pressure (MAP)
- 2) Manifold Air Temperature (MAT)
- 3) Coolant Temperature (ECT)
- 4) Throttle Position (TPS)
- 5) Exhaust Oxygen (O₂)

MANIFOLD AIR TEMPERATURE SENSOR

The Manifold Air Temperature sensor, is a thermistor device which measures air temperature. This sensor must be installed into the air cleaner base. Drill the air cleaner base with a 3/4" drill, deburr any sharp edges, install MAT sensor grommet, then slide sensor into grommet.

NOTE: The systems that have the MAT sensor in the intake plenum area, can be moved to the air cleaner if necessary to obtain additional vacuum ports.

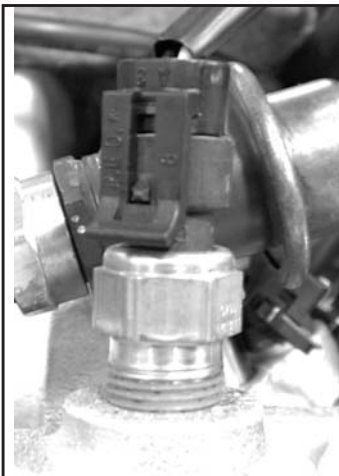

COOLANT TEMPERATURE SENSOR

The Coolant Temperature Sensor is a thermistor device like the Manifold Air Temperature sensor. Resistance varies as coolant temperature rises and lowers. The Coolant Temperature Sensor is located at the front of the manifold on the driver's side.



THROTTLE POSITION SENSOR

The Throttle Position Sensor, an integral part of the Pro-Flo throttle body, measures throttle angle. This sensor requires adjustment as described in the SYSTEM START-UP section of this manual.



MANIFOLD ABSOLUTE PRESSURE SENSOR

The Manifold Absolute Pressure sensor, mounted on the air valve with a bracket, converts air pressure (load) in the manifold, to an analog signal sent to the ECU. For more information on Manifold Absolute Pressure, refer to the section on Speed Density Electronic Engine Management.

OXYGEN (O₂) SENSOR

An oxygen sensor, installed on the header collector pipe, measures exhaust gas oxygen content and is used by the ECU to manage fuel delivery under closed loop control. Installing the sensor requires drilling a 1/2-inch hole in the passenger-side header collector. The sensor is held in place with the provided fitting which must be professionally welded into place. The red-lean/green-rich light on the Calibration Module is also controlled by the O₂ sensor. The O₂ sensor is connected to the Main System Harness by Connector J18. For installation details, refer to the FUEL SYSTEM section of this manual.

NOTE: The Pro Flo system is capable of using either a narrow band or wide band O₂ sensor. The difference between a narrow band and wide band O₂ sensor is the range over which the sensor is accurate. A narrow band sensor is basically a switch that only tells the ECU if the air fuel ratio (AFR) is richer or leaner than 14.7 to 1. A wide band sensor/controller typically has a linear voltage output that is accurate over a range of 10 to 20:1 AFR. The included wideband sensor calibration is for use with the Dynojet Wide Band Commander Air Fuel Ratio Monitor. See <http://www.widebandcommander.com> for more information. To select the wideband option, install the included O₂ select jumper as shown below. To use the default narrow band option, leave the jumper off. A dust cap is provided for protection when the connector is not used. The wideband sensor input is located on pin 31 of the larger 34 pin main ECU connector. Using the supplied ECU terminal pigtail, insert the pigtail by depressing the white terminal lock on the connector. Insert the terminal into pin 31, then close the terminal lock by pushing it in the other direction. Connect the wideband controller output to the pigtail.

O₂ SENSOR INSTALLATION

NOTE: It is recommended that the O₂ sensor installation be performed by a professional muffler shop.

1. Double check header gaskets, replacing if necessary.
2. Drill a 1/2-inch to 9/16-inch hole in the passenger-side header collector reducer, as close to the header flange as possible. (1" to 3" away)

NOTE: Before drilling, make sure the O₂ sensor will be mounted horizontally and within reach of the harness connector. Check to ensure adequate clearance for the sensor, taking into consideration engine movement.

3. Fit the provided fitting into the hole in the exhaust pipe and weld into place.
4. Once it has been welded into place, clean the threads in the center of the fitting. If your exhaust is coated tap bung threads to ensure a good ground for the O₂ sensor.
5. Thread the O₂ sensor into the fitting. A high-heat anti-seize compound is included and needs to be applied to the sensor threads.

NOTE: The O₂ sensor has 18mm x 1.25 spark plug threads.

6. Attach the O₂ sensor to the main system harness. Refer to the MAIN SYSTEM HARNESS section of this manual.

NOTE: UNLEADED FUEL IS RECOMMENDED TO BE USED ONCE THE O₂ SENSOR HAS BEEN INSTALLED.

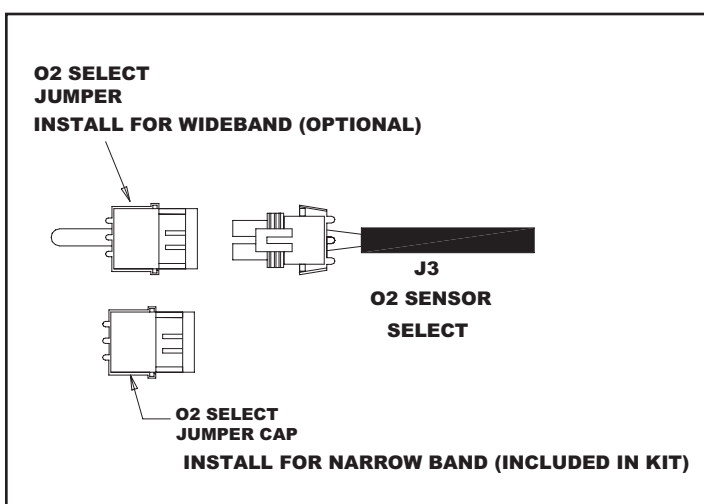
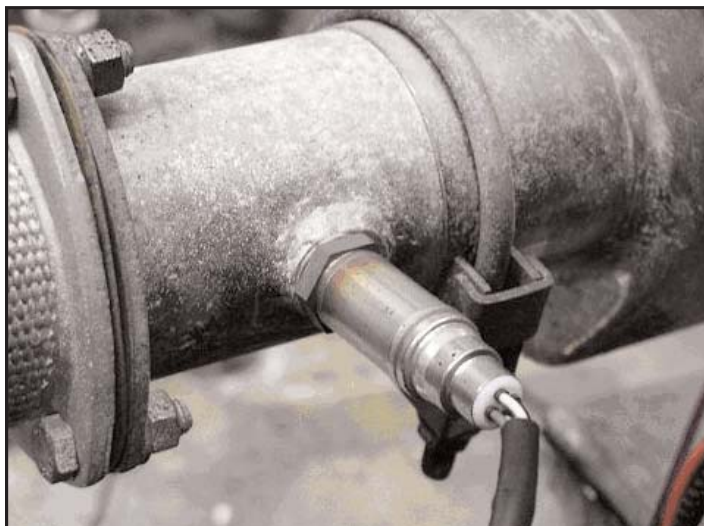

INSTALLATION

Refer to the Harness Layout diagram on page 18 for further details.

1. Inspect the Main System Harness, making sure that all connectors and grounds are properly in place.
2. Because the harness extends from the engine compartment into the passenger compartment, a hole must be drilled in the firewall on the passenger side. Cut two overlapping 1 1/4-inch holes on a 1-inch center in the firewall. Saw the pointed edges to create an oval-shaped hole.

NOTE: An alternative to this method is to cut a single 1 3/4 inch hole.

3. Extend the fuel pump relay, ECU connector, and Calibration Module relay through the firewall hole into the passenger compartment.

NOTE: The T-connectors at the joints of the Main System Harness are closed by snap fasteners which can be opened by hand or with a flathead screwdriver. Once open, the T-connectors can be rotated for ease of installation, if necessary.

4. The aluminum plate included on the harness mounts over the firewall hole using four hex head sheet metal screws.

NOTE: Start the screw holes with a pointed punch or small drill.

5. The wire harness is assembled with the aluminum plate flush against a T-connector. The black plastic casing on the wire harness can be cut to allow the plate to slide up the harness to the correct location. Once the harness is in place, the casing should be reattached on both sides of the firewall.

CAUTION: When feeding the wire harness through the firewall, be careful to not damage the wires against the cut sheet metal.

6. A rubber grommet is provided to protect the wires in the aluminum plate. Use RTV to seal the plate to the firewall.
7. Install all connectors according to the list and diagrams.



The Throttle Position sensor attaches to the harness with Connector J5.



The Manifold Absolute Pressure sensor attaches to the harness with Connector J17.

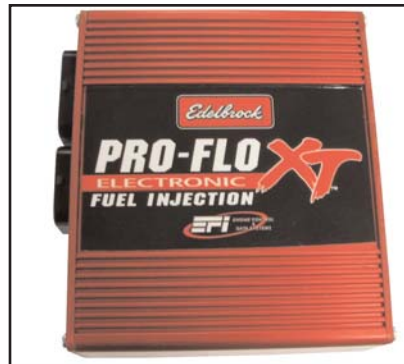

ELECTRONIC CONTROL UNIT / SYSTEM ECU

The Electronic Control Unit (**ECU**) must be mounted away from moisture, excessive heat, or vibration. Underneath the dashboard on the passenger side, or behind the glove box are recommended locations.



The Coolant Temperature sensor attaches to the harness with Connector J15.



The Manifold Air Temperature sensor attaches to the harness with Connector J16.

MAIN SYSTEM HARNESS

This diagram illustrates the entire Pro-Flo Main System Harness.

O2 SELECT 2 POSITION METRI-PACK FEMALE
 SHELL: 12052644
 CONTACT: 12084200
 CABLE SEAL: 12089678

DISTRIBUTOR 3 POSITION WEATHER-PACK TOWER
 SHELL: 12015793
 CONTACT: 12089188
 CABLE SEAL: 12015323

T.P.S 3 POSITION METRI-PACK FEMALE ASSY
 SHELL: 12162182
 CONTACT: 12124075

COIL 3 POSITION WEATHER-PAK TOWER
 SHELL: 12015793
 CONTACT: 12089188
 CABLE SEAL: 12015323

J1
 ECU CONNECTOR
 HOUSING: AMP 2-1437285-3
 TERMINAL: AMP 3-1447221-3

J2
 ECU CONNECTOR
 HOUSING: AMP 2-1437285-2
 TERMINAL: AMP 3-1447221-3

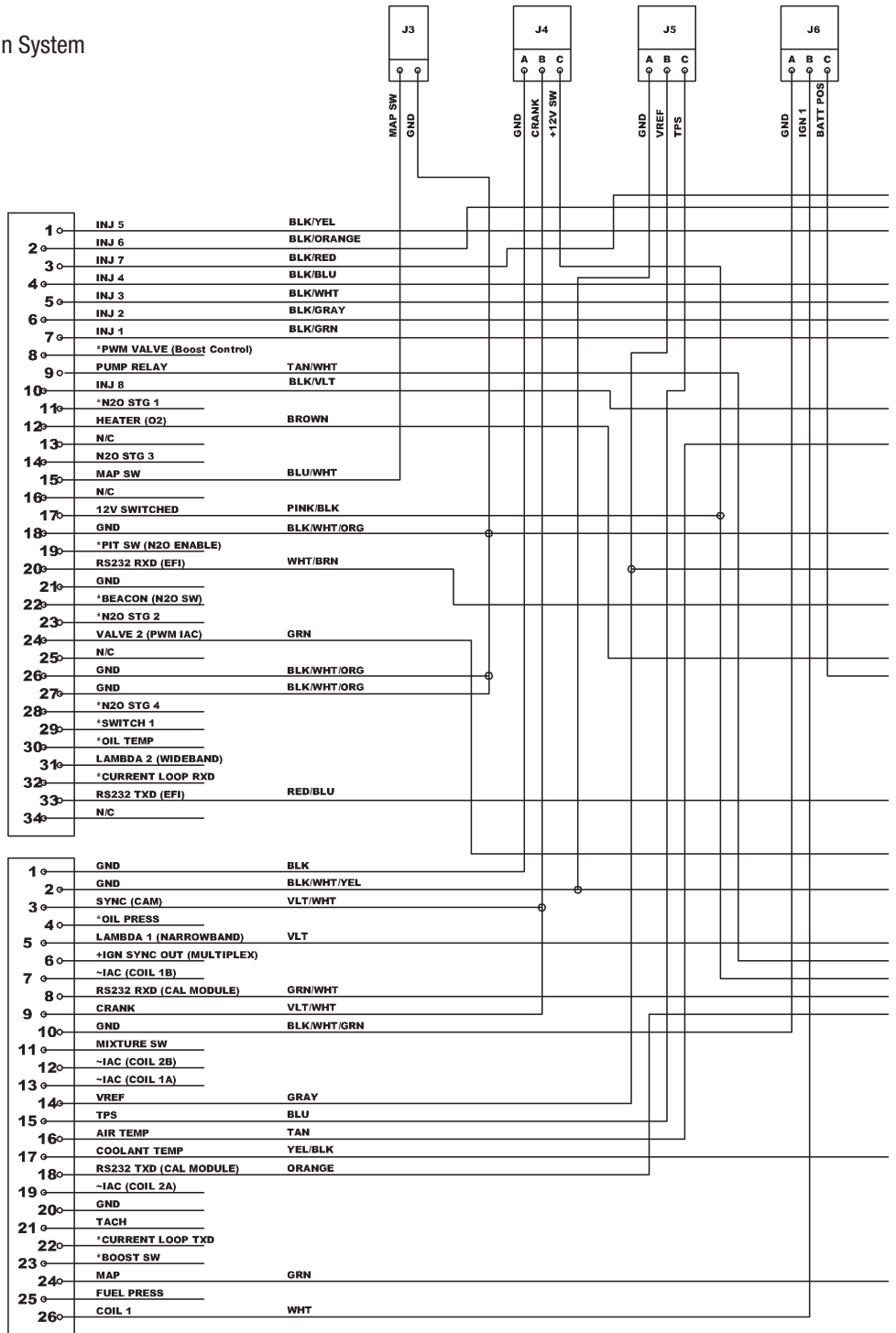

* PRO FLO XTR SYSTEMS ONLY
 ~ PRO FLO XT/XTR SYSTEMS ONLY
 + FOR USE WITH MULTIPLEX COIL DRIVER ONLY

HARNES LAYOUT

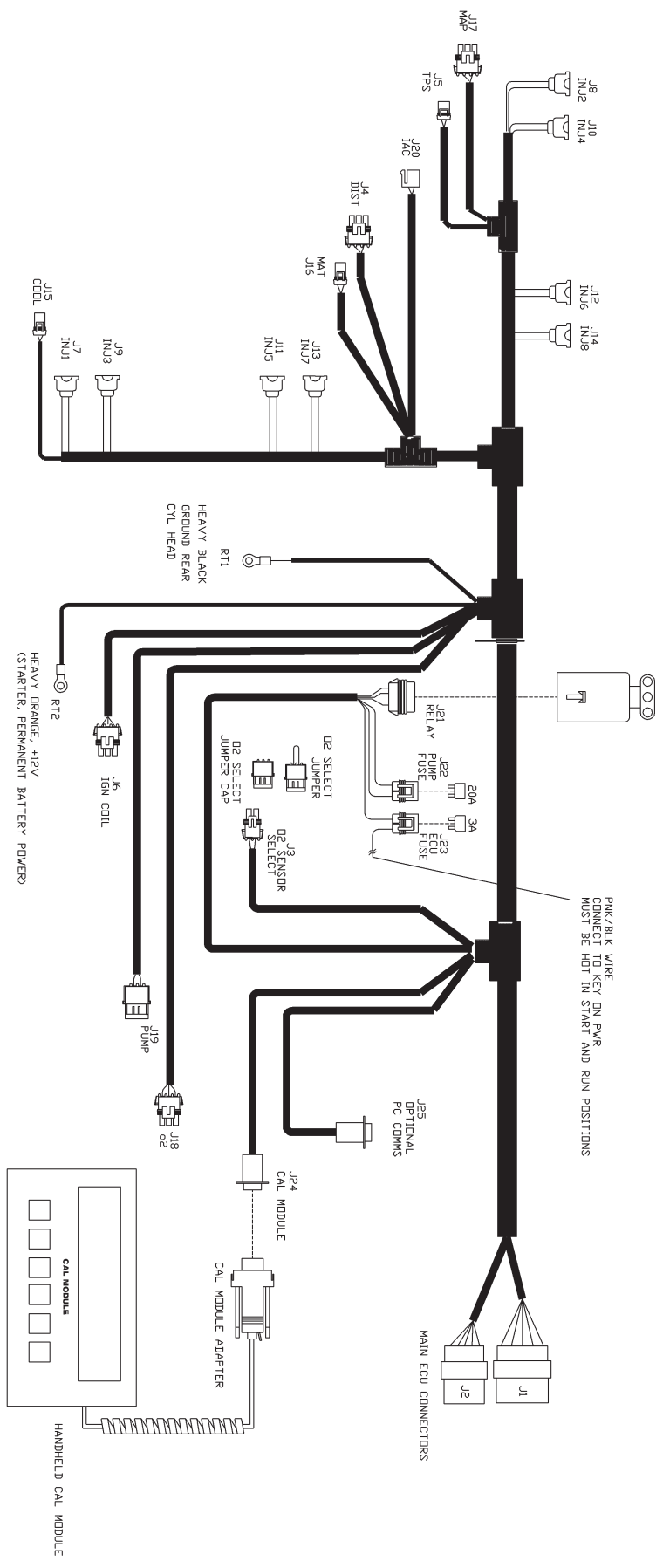

The fuel injector connectors are identical, but they are placed in logical sequence. Refer to the diagram when installing the harness connectors to the fuel injectors. In addition to the Main System Harness, the Pro-Flo system includes these shorter harnesses:

- A. Ignition Coil to Main System Harness
- B. Fuel pump to Main System Harness



A.

This 3-foot ignition harness is attached to the distributor cap with the connector at right above, and at the main wiring harness with the connector on the left above. The ground goes to the rear of the cylinder head. When used with a small cap distributor or any distributor with an external ignition coil, this harness must be slightly modified. The three wire leads at the distributor connector (on the right below), must be cut from the connector (or released with a small screwdriver) and individually routed using the provided terminals. The black wire may be removed between the connection on right above and the 3/8" ring lug. The 3/8" ring lug must still be grounded on the rear of cylinder head. The red and brown wires are routed as follows:



RED: ignition coil positive (+) terminal.

BROWN: ignition coil negative (-) terminal Sleeves and tie-wraps are provided to fit over the terminals once the wires are installed.

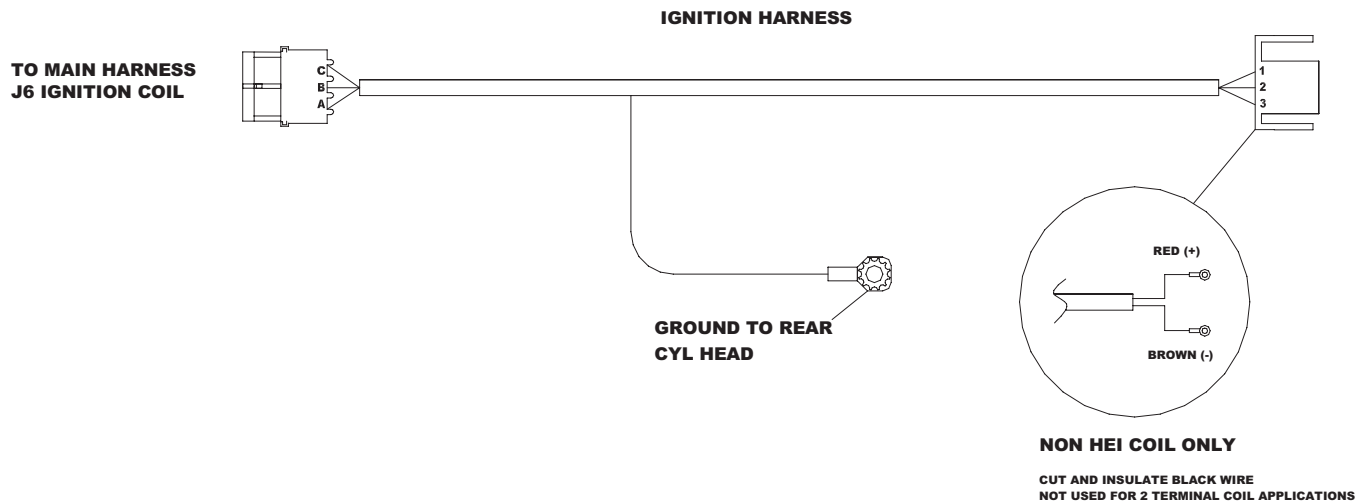

B.

The connector on left end (as drawn) of this 10-foot fuel pump wiring harness attaches to the Main System Harness. The two connectors on the right connect to the positive (+) and negative (-) terminals on the fuel pump. A sleeve and tie-wrap are provided to fit over the positive terminal once the connector is installed. This sleeve prevents the clamp from shorting the fuel pump terminals.

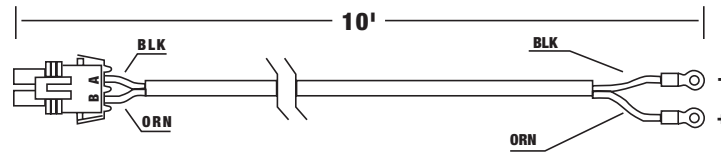

The diagram below shows how the distributor, ignition harness, and Main System Harness are connected.

NOTE: The connectors for the distributor hookup (J4) and coil harness hookup (J6) are identical. Refer to the wire colors shown below and the harness diagram on page 18 for proper installation.

A KEY ON wire (Pink with black stripe) is also included in the Pro-Flo system. This wire connects to the fuse box. Make sure there is power with the key on and also while cranking.

REFER TO VEHICLE REPAIR MANUAL FOR WIRING DIAGRAM, IF NECESSARY.

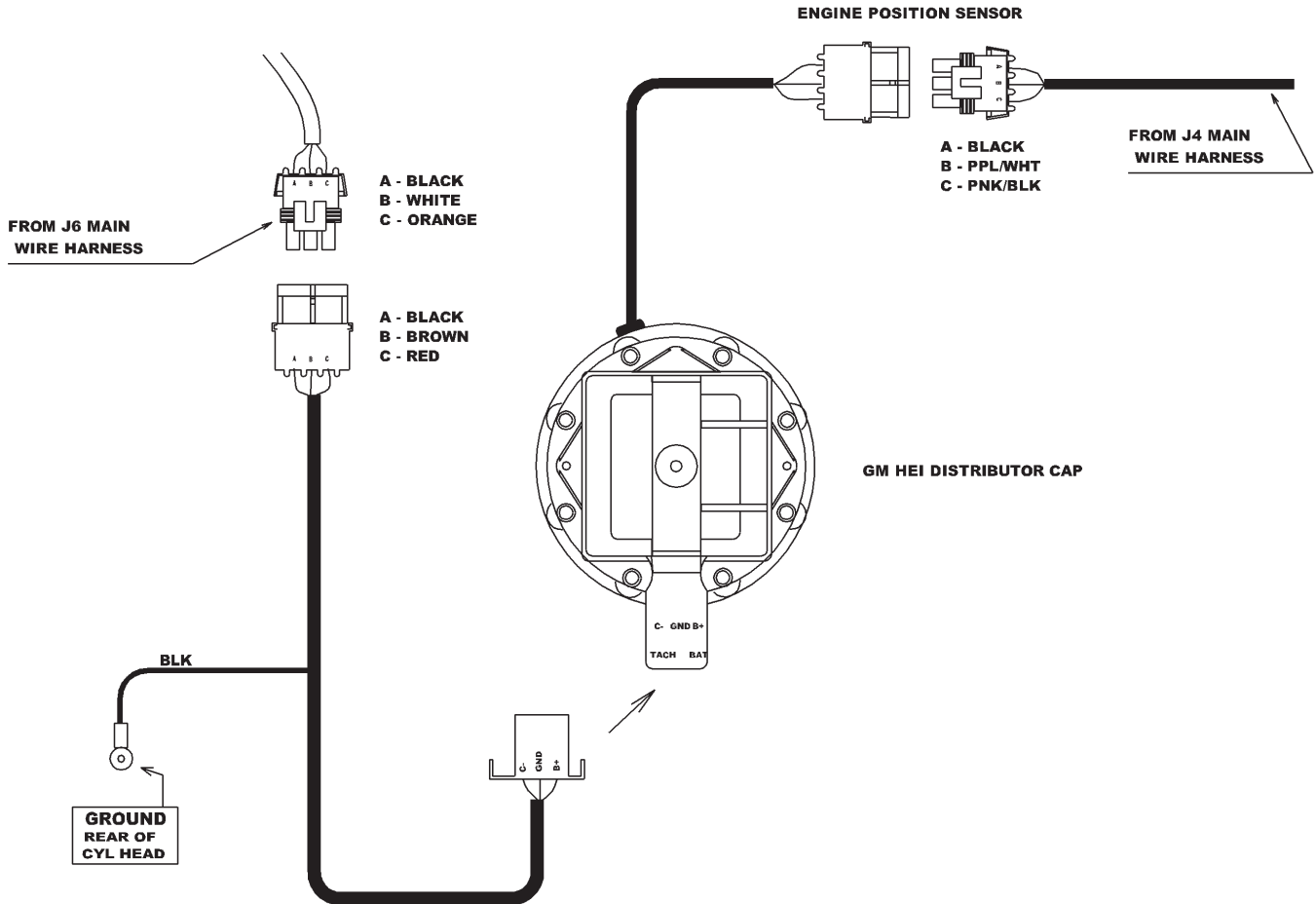

IGNITION SYSTEM

A new distributor is not required with the Edelbrock Pro-Flo system. The system has been designed to allow you to convert your stock distributor, large cap or early small cap, mechanical or computer-controlled, into a Multi-Port Fuel Injection compatible Hall effect electronic distributor. Optional conversion distributor bodies are the MSD #8365 and Accel #9109. A Mallory #6148201 may be used as is, without performing the conversion.

HALL EFFECT SENSOR

A Hall effect distributor operates with a sensor that generates a pulse train indicative of engine position and speed. This type of distributor is required for sequential fuel injection, and also provides high ignition timing accuracy. The Pro-Flo system includes everything you need for this distributor conversion. The conversion is a simple matter of disassembling your stock distributor and installing the Hall effect sensor, sensor plate, and shutter wheel provided with the package. Since the ECU controls spark advance, a mechanical advance lock-out plate is provided as well.

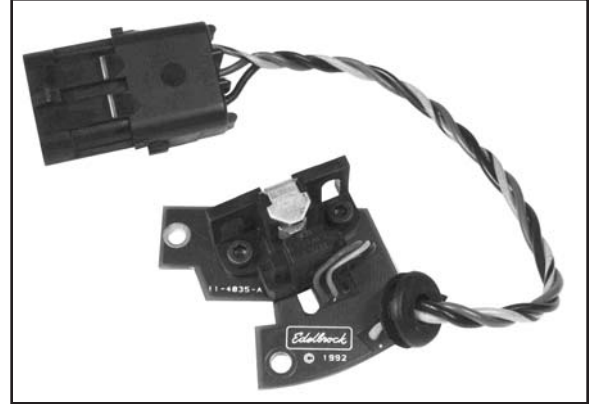

SHUTTER WHEEL

The Hall effect shutter wheel is designed with seven wide shutter teeth and one narrow shutter tooth. The narrow tooth indicates the Number One cylinder position, and is necessary for the ECU to establish proper phasing of the injector firing order. For this reason, correct installation of the shutter wheel is very important. If the shutter wheel is installed incorrectly, the injector firing order will not begin with the Number One cylinder.

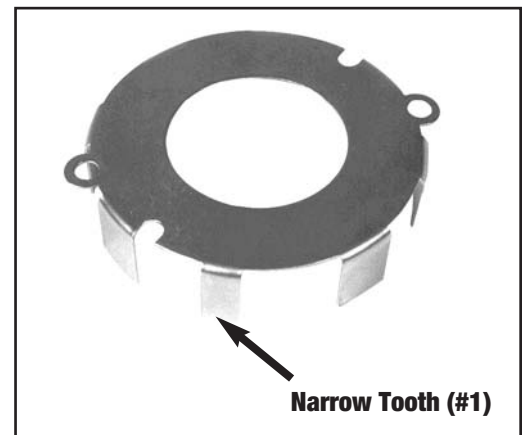

DISTRIBUTOR CONVERSION

1. Rotate the engine to 10° Before Top Dead Center (BTDC) on cylinder #1 as seen on the damper, with the rotor pointing approximately to Number One cylinder plug wire.
2. Remove the distributor cap.
3. Remove the distributor from the engine.
4. Note position of rotor and mark the distributor housing where the rotor points to Number One cylinder.
5. Remove the roll pin from the bottom of the distributor shaft, releasing the drive gear and shims.

NOTE: Check the drive gear and oil pump drive shaft for signs of wear. Worn parts can damage the camshaft and oil pump and should be replaced. This is especially true when a high performance oil system is used, which generates a heavier load on the camshaft gear system.

6. Remove the rotor and distributor shaft.

NOTE: It is critical that the sensor plate fits securely in place and is level in relation to the distributor housing.

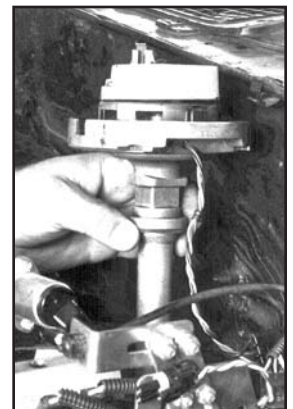

7. Remove all internal components from the distributor housing, including the vacuum advance diaphragm.



8. Install the electronic Hall effect sensor and sensor plate, using the fasteners provided. The sensor plate has been designed to fit into a small cap or large cap distributor. Only the fastening holes and sensor position differ. The circuit board comes factory set for large cap applications. For small cap distribution move the sensor to other mounting holes. See small cap section on next page.

NOTE: It is critical that the sensor plate fits securely in place, and is level in relation to the distributor housing.

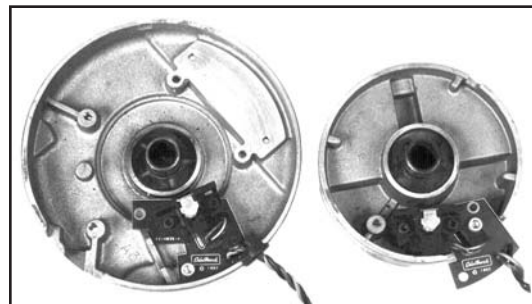

9. Install the shutter wheel on the bottom of the rotor mounting plate. The shutter wheel cannot be installed from above the mounting plate and must be installed from the drive gear end of the rotor shaft. The shutter wheel is fastened to the rotor mounting plate by two screws. On small cap distributors, it is necessary to first install the provided aluminum ring spacer above the shutter wheel. When properly installed, the notched end of the rotor mounting plate will be farther from the narrow shutter tooth.

NOTE: On small cap distributors, it may be necessary to file the stud holes of the shutter wheel to fit.

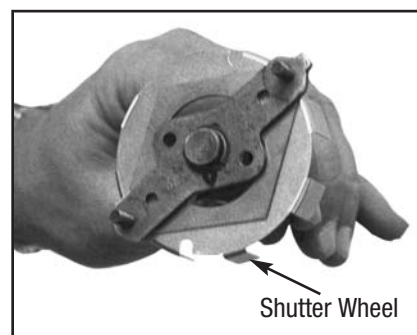

10. If you are converting a mechanical advance distributor, the advance assembly weights should be discarded. Replace them with the provided lock-out plate or weld. Secure the lock-out plate with the stock springs. If possible, have the shaft Tig welded to the rotor plate by a professional. If not, apply a small amount of RTV silicone to the underside of the rotor plate, and on each of the studs prior to installing the lock-out plate.

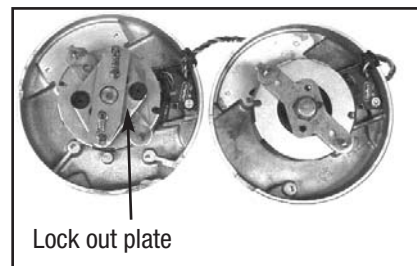

11. Reinstall the distributor shaft into the distributor. The shutter wheel teeth should pass through the Hall effect sensor without touching on either side of the sensor. The shutter wheel teeth may be carefully adjusted by hand to ensure clearance if necessary.

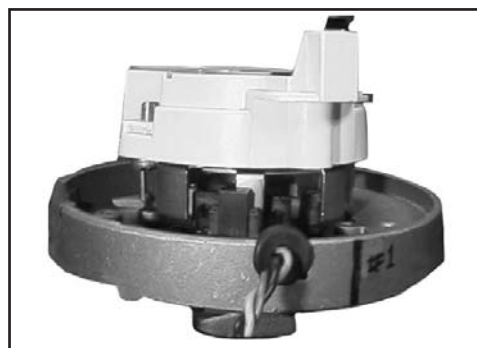

12. When the drive gear is installed, the shutter wheel teeth must be deep enough into the Hall effect sensor to allow them to completely pass through the sensor at the proper depth, but not so deep as to make contact with the sensor. On small cap distributors, the provided spacer must be used to provide correct spacing for the shutter wheel. On large cap distributors, diamond-shaped shims are provided to allow for adjusting shutter wheel height.

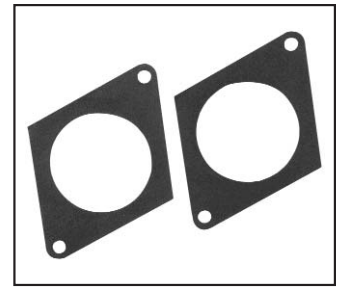

13. Install the drive gear, shims, and roll pin to the bottom of the distributor shaft. Shaft end play should be .015" to a maximum of .030".

14. Hand turn the rotor in the distributor to make sure that the shutter wheel is deep enough into the sensor that no binding occurs, and to check for correct clearance between the shutter wheel teeth and the sensor. Shutter wheel teeth should not come up out the tapered area of the sensor.



Shutter wheel tooth and sensor Alignment.

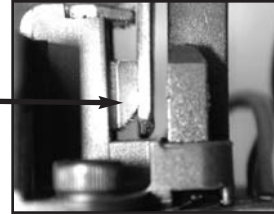

15. If clearance is correct, drop the rotor over the screen studs and fasten with supplied lock washers and nuts. Thread sealing compound is recommended as added insurance.

16. When installing the shutter wheel and re-attaching the rotor, check that when rotated clockwise the leading edge of the narrow shutter wheel tooth is centered in the Hall effect sensor when the rotor is pointing to the Number One cylinder position.

17. Be sure to test your distributor as described on the following page prior to re-installation.

SMALL CAP DISTRIBUTOR CONVERSION

Adapting a small cap distributor to the Pro-Flo Hall effect system requires a few additional steps in the conversion. Note: Some cast iron distributors will require modification to fit the Hall effect sensor plate. You will need to use a mill or die grinder to remove material as needed.

1. The Hall effect sensor mounts with different fastening holes on a small cap distributor. Refer to the photo with Step 8 above for correct sensor position.

2. The small cap distributor requires the installation of the provided spacer above the shutter wheel. Refer to the photo at Step 11 above.

3. To use the shutter wheel on small cap distributors, it is necessary to first file the stud holes of the shutter wheel to fit with the provided fasteners. The holes must be filed approximately 0.030-inch. As shown at right. This modification provides clearance between the fillister screw heads and the teeth next to these slots. On some small cap distributors the head of these screws may have to be filed to clear the top of the hall sensor.

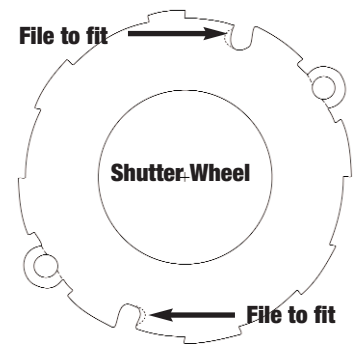

4. In order to use the Pro-Flo system with a small cap distributor, or any distributor utilizing an external ignition coil, it is necessary to modify the 3-foot ignition amplifier harness. Refer to page 21, the MAIN SYSTEM HARNESS section of this manual for details.

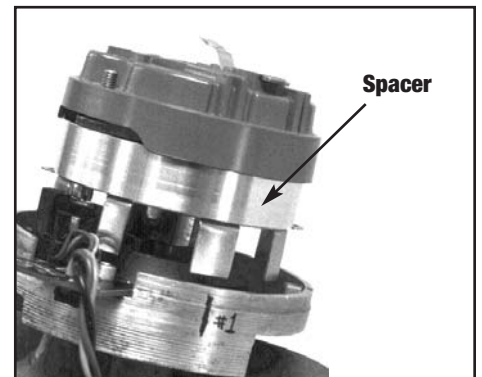

DISTRIBUTOR TESTING

Before re-installing the distributor, test to ensure that the conversion has been performed correctly.

1. Install the ECU and wiring harness and make all connections except the distributor.
2. Disconnect electrical connections at the fuel pump. Unplug the 10-foot fuel pump harness from the Main System Harness. Refer to the MAIN SYSTEM HARNESS section of this manual for details.
3. Turn the key to the ON position without starting the engine.
4. The Pro-Flo Calibration Module will receive power and display an RPM: 0 reading, among other parameters.
5. Connect the distributor to the wiring harness and spin the distributor gear by hand. If the distributor sensor is operating properly, the main fuel pump relay will click on. When the distributor stops spinning, the Calibration Module may display NO COMMUNICATION for approximately 2 seconds. This is normal and indicates that the ECU is waiting for the next distributor signal before the allowed time expires.
6. If the relay clicks on as indicated in step 5, re-install the distributor.

REINSTALLING THE DISTRIBUTOR

1. Make sure that the distributor sits completely down on the manifold boss and that the drive gear has fully engaged the oil pump drive.
2. Lift the rotor by hand to make sure that there is adequate endplay. Lack of endplay indicates that the rotor shaft is bottomed out on the oil pump shaft.
3. Gaskets may be added at the bottom of the distributor shaft above the drive gear to adjust the endplay on either large cap or small cap distributors. Add gaskets one at a time, checking that the rotor shaft maintains sufficient endplay to prevent damage to the bushings. Recommended endplay is between 0.015- and 0.030- inch.
4. Adjust the housing to ensure that the leading edge of the narrow shutter wheel tooth is centered in the Hall effect sensor when the engine is at 10° BTDC on #1 cylinder.
5. Lightly tighten the hold down clamp so that the distributor can still be turned to determine final setting when checking the timing
6. Re-attach the distributor cap, with the rotor pointing towards the No. 1 terminal.
7. The distributor is connected to the Main System Harness with connector J4.
8. A short ignition harness connects the distributor cap to the main harness, and to ground at the rear of the cylinder head. Refer to the MAIN SYSTEM HARNESS section of this manual for more details.

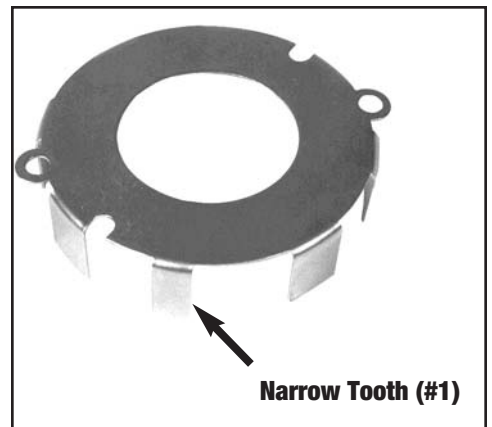

ADDING AFTERMARKET IGNITION

If you are wishing to use a MSD 6AL or MSD 6-Digital ignition with your Pro-Flo fuel injection, follow the wiring diagram below.

NOTE: When installing the MSD box, keep the red battery lead, the main MSD box, and the power leads to the ignition amplifier AWAY from the ECU and it's wires. Failure to do so will cause serious communication and running issues.

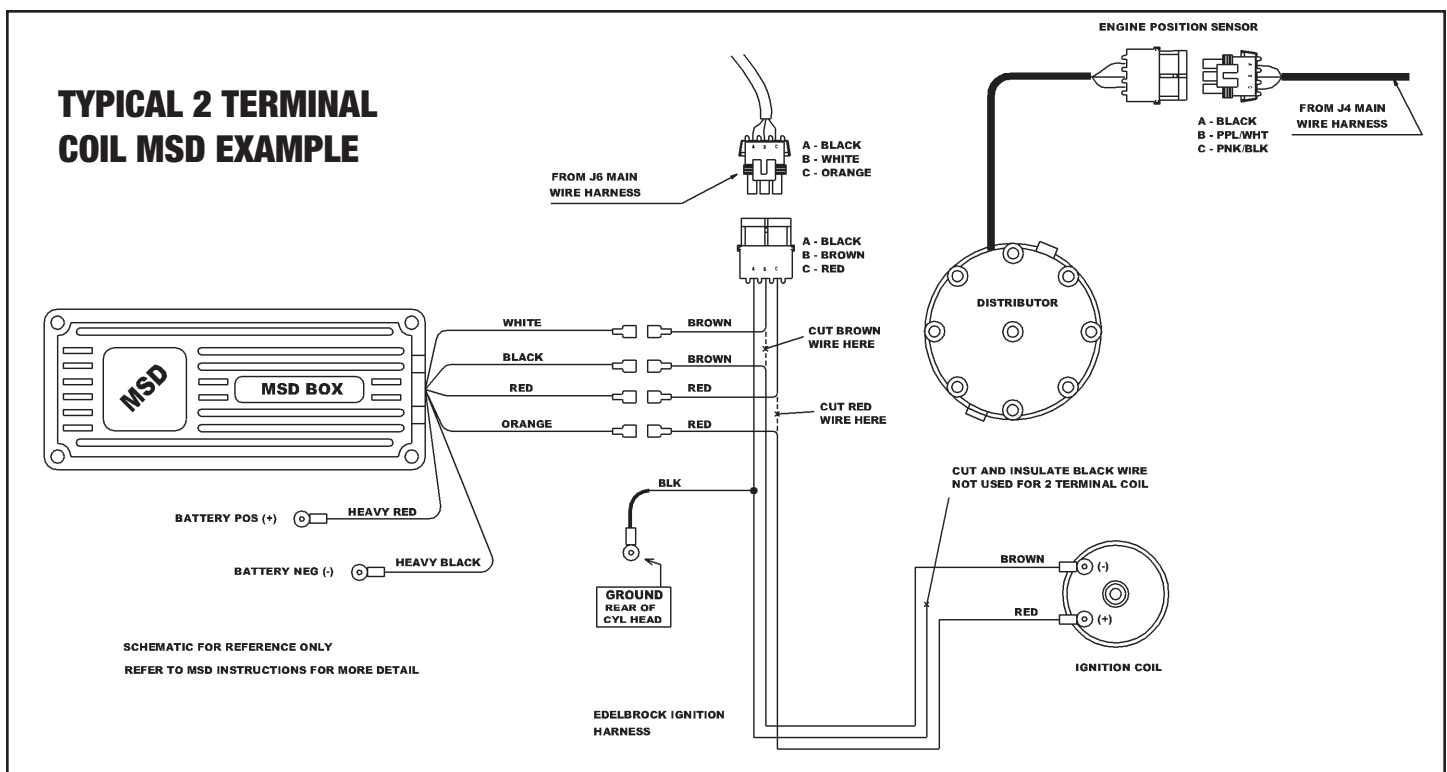
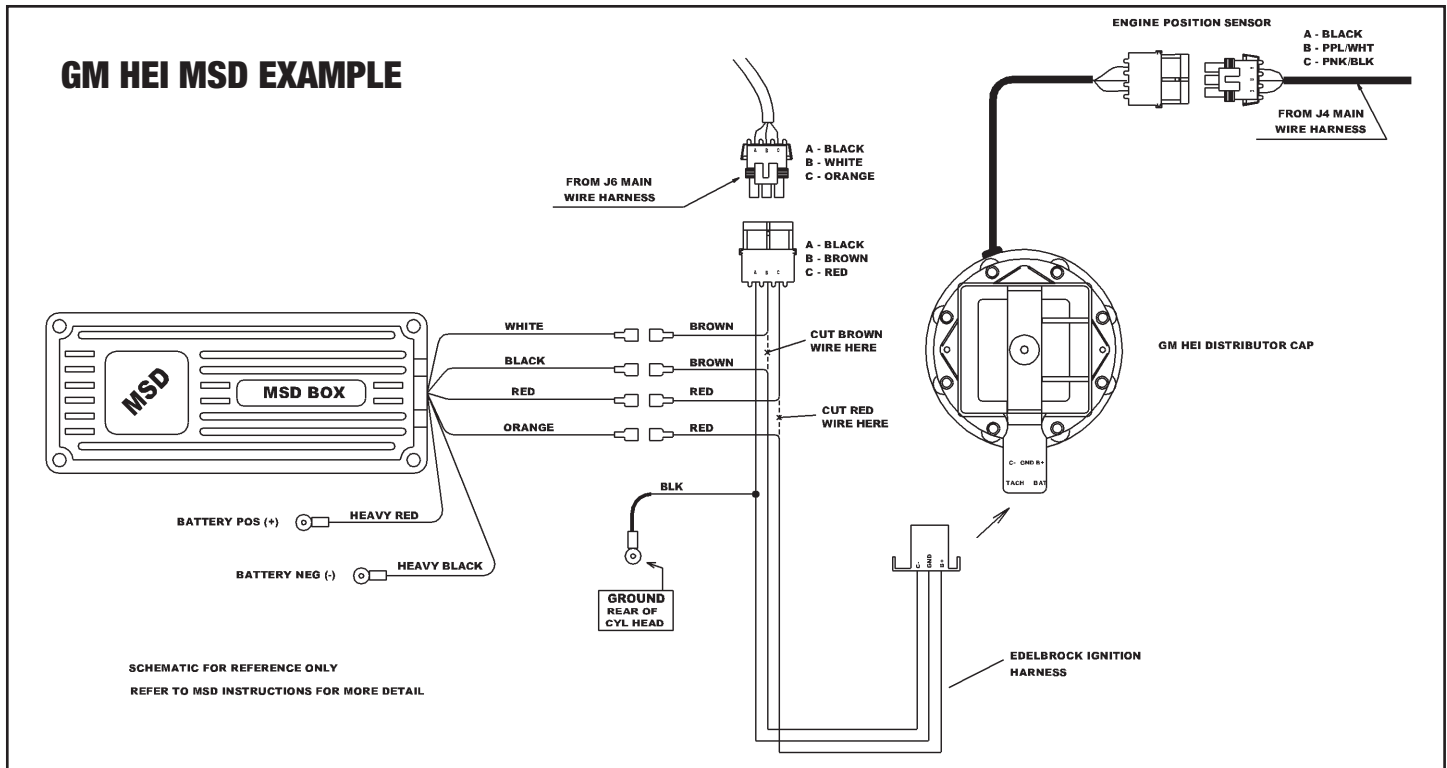

INSTALLING THE SOFTWARE

The software package included with the Pro Flo kit is required to load the initial calibration file into your ECU. An optional software package called *bEditor* is also included on the supplied CD-ROM.

To install the software, load the supplied CD into your PC's CD drive. The installation routine should auto run. Follow the onscreen prompts to install the software.

eFlash is a stand alone system that can be used to load calibration files or different firmware versions onto an ECU using any Windows compatible PC. A laptop is not required. The system includes a DC power source that can be plugged into any standard wall socket. It will provide power to the ECU and allow two way communication without having to install the ECU in the vehicle. Tuning can then be done using the handheld module. In addition to allowing flash programming, eFlash has several additional features that can be useful.

- It displays all ECU data real time in one consolidated view.
- It displays all calibration module trims and modifications in one view so you can see them at a glance.
- It allows Edelbrock tech support personnel to view your ECU data real time using the iLink feature (internet connection required)
- It allows you to send your existing calibration file to Edelbrock tech support personnel using the iLink feature (internet connection required).
- It allows the user to perform software updates if necessary.



Shortcut to
eFlash

To open the eFlash utility double click on the eFlash desktop icon.

To connect the ECU to your PC, plug the 34 pin ECU connector into the ECU. The connector will only plug in one way. Connect the DB9 serial connector to your PC either directly or through an extension cable (not included). Plug the AC Power Adapter into a standard wall socket.

NOTE: A USB to Serial converter is included with the kit to be used if your PC does not have a 9 pin serial port. Connect the USB end of the adapter to your PC and the serial port (9 pin) end to the power adapter harness. Follow the instructions included with the USB adapter to install the appropriate drivers. Go to File - Port Settings in eFlash and select the com port that matches the location of the adapter.

Confirm that the ECU is connected and communicating with eFlash. "ECU Connected" should be displayed in the lower left hand corner as shown to the right.

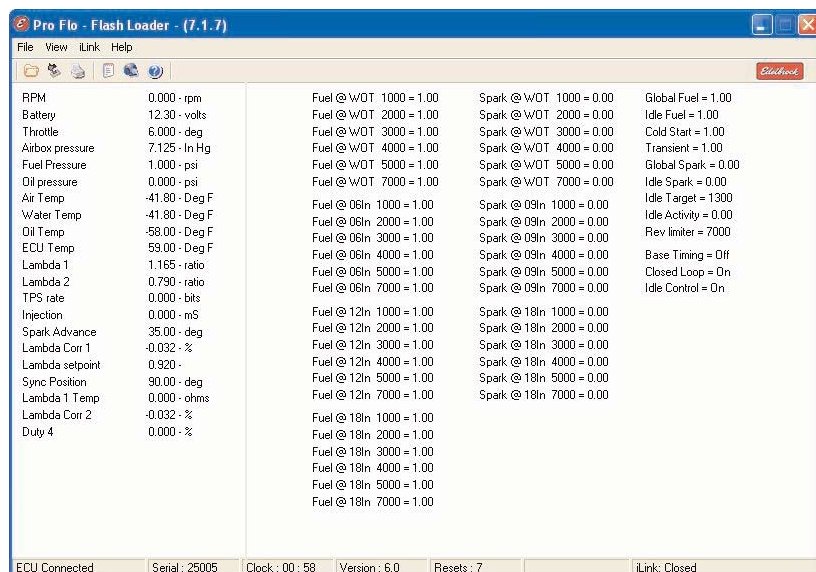

SELECTING THE PROPER CALIBRATION

Please refer to the calibration selection guide on the CD to determine the appropriate calibration for your application to load into the ECU. Use caution if using the calibration included in the ECU from the factory as it may need extensive changes to achieve a proper tune and could cause engine damage if not corrected.

To load a new calibration file into the ECU, go to File - Load New Map



NOTE: Edelbrock recommends a minimum of 112° for intake lobe separation angle on all Pro-Flo EFI applications. A value less than this may make tuning more difficult depending on the intake duration.

The calibration files are saved in folders identified by kit part number. Double click on the folder with your kit part number, then select the calibration that corresponds to your camshaft duration. The eFlash utility will load the calibration into your ECU. Follow the on screen prompts to complete the process. When the software prompts you to cycle power, simply remove the connector from the ECU, wait 5-10 seconds, then plug it back in and hit OK. When finished, close the eFlash program and disconnect the power adapter connector from the ECU. You are now ready to connect the ECU to the vehicle harness. Additional information can be found in the help file included in the software.

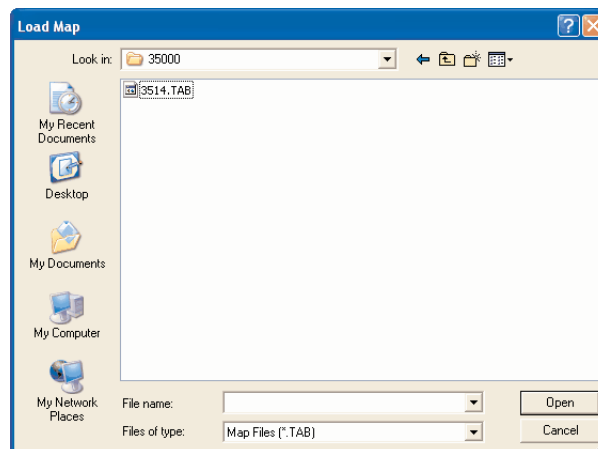
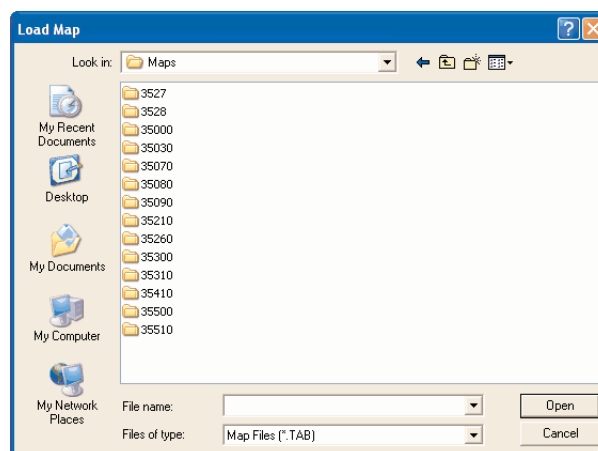

OTHER APPLICATIONS

The Pro-Flo system has been designed and calibrated specifically using the Chevrolet 454 c.i.d. Big-block with large-valve style cylinder heads (such as Edelbrock's Performer RPM Street Cylinder Heads with 2.25-inch valves) and tubular headers as a baseline. It is unlikely that every engine on which the Pro-Flo system is installed will match this baseline combination. The system can be used with similar applications, as long as the correct chip matching your cam profile is installed in the computer and necessary fuel calibration adjustments are made. If your Big-block is not a 454, does not have headers, and uses small-valve style cylinder heads (such as Chevrolet aluminum HO heads with 2.02-inch valves), it may require additional tuning adjustments. For further information refer to the SYSTEM SET-UP SECTION of the Owner's Manual.

If you are running small-valve heads and/or you are not using tubular headers, it may be necessary to adjust the air/fuel ratio at WOT from 4000 rpm and up. Refer to the table below for starting points for adjustments. Refer also to the SYSTEM SET-UP section in the Owner's Manual. Use the FUEL @ WOT screens (located under FUEL MODIFIERS) to adjust the fuel at each available RPM. It should not be necessary to lean the fuel calibrations at 12" or 18" vacuum.

WARNING: Watch the Rich/Lean light on the Calibration Module. If the light indicates a lean condition (red) for more than a fraction of a second at 06" vacuum or WOT you are too lean for safe engine operation at full load.

SYSTEM START-UP

Once the Edelbrock Pro-Flo system has been installed, there are a few procedures you must follow to break-in the system. Carefully performing these break-in procedures will ensure best results and optimal performance.

Use this checklist to double-check the following areas **BEFORE** starting the car:

- | | |
|---|---|
| <input type="checkbox"/> Has the battery been reconnected? | <input type="checkbox"/> Have all fuel lines been reconnected? |
| <input type="checkbox"/> Has the radiator been refilled with coolant? | <input type="checkbox"/> Has the exhaust system been completely re-installed? |
| <input type="checkbox"/> Has the gas tank been refilled? | <input type="checkbox"/> Has the O ₂ sensor been installed and connected? |
| <input type="checkbox"/> Has the oil been replaced? | <input type="checkbox"/> Have resistor type spark plugs been installed? |
| <input type="checkbox"/> Have all linkages been reconnected? | <input type="checkbox"/> Has the calibration module been connected to the main harness? |
| <input type="checkbox"/> Have all wiring harness connectors been connected? | |

Priming The Fuel Pump

Before the engine is started, the fuel pump must be primed to pressurize the system and purge the fuel line of all air.

1. Turn ignition key to the ON position. You should hear the fuel pump go on. It will pump for 2 or 3 seconds and disengage.
2. Turn the key to the OFF position for 1 second.
3. Turn the key to the ON position again. The pump will go on for another 2 or 3 seconds.
4. Repeat this procedure until the pump has been cycled three or four times, and is primed. The tone of the fuel pump will change when all air is out of the fuel system.
5. If there is no tone, or no change in tone, the system is not priming. Check the entire fuel system for leaks, from the fuel tank to the injectors.

Testing The Sensors

Before starting the engine, test all sensors.

1. Turn the key to the ON position with the Calibration Module connected. The display will read:

RPM: 0 FUEL: 0.0 mS VAC: 0.0" Hg SPK: 10°
--

NOTE: A vacuum reading of other than 0.0" Hg may be displayed depending upon barometric pressure and air temperature. At extreme altitude, the vacuum reading may be as high as 5.0" Hg.

2. Push the UP ARROW key once to display.

TH20: 76°F	TPS: 13°
TAIR: 77°F	Volt: 12.0

NOTE: The water and air temperatures displayed will vary depending on ambient conditions. The system voltage will vary depending on the condition of the battery.

3. Move the throttle to test the Throttle Position Sensor (TPS). The TPS reading should vary depending on throttle angle.
4. If the calibration module goes blank while cranking, the system is losing power. Check the Pink/Black wire attached to the 3 Amp fuse for +12V power with the ignition in the crank position and the run position for proper operation.

Timing Adjustment

Use a timing light to re-time your engine. The following steps must be performed after the induction system has been installed and the distributor has been converted and re-installed. Refer to the INDUCTION SYSTEM and IGNITION SYSTEM sections of this manual.

1. Remove spark plug from Number One cylinder.
2. Remove coil wire from distributor and ground it.
3. THIS STEP REQUIRES TWO PEOPLE OR USE OF A REMOTE STARTER SWITCH. While one person rotates the engine by slowly bumping the starter, the other holds his finger over the Number One plug hole until compression is felt.
4. Continue to bump starter until timing mark on the crankshaft pulley shows approximately 10 degrees Before Top Dead Center.
5. Position rotor to approximately align with the Number One cylinder plug wire terminal in distributor cap. Check that the leading edge of the narrow tooth on the shutter wheel (as the shutter wheel rotates clockwise) is centered in the sensor. Refer to the IGNITION SYSTEM section in this manual for details.



Setting Base Spark Advance

Use a timing light and the Pro-Flo Calibration Module to accurately set timing.

1. Start the engine

2. The Calibration Module screen will display this screen:

**RPM: 0 FUEL: 0.0 ms
VAC: 0.0"Hg SPK: 10°**

3. Press the DOWN ARROW key once to reach this screen:

**<MISC.MODIFIERS>
ENTER to select**

4. Press the ENTER key to display this screen:

**Target Idle RPM:xxxx
MODE ↓↑ = SCROLL ENTER**

5. Press the UP ARROW key six (6) times until the module displays this screen:

**Base Tim'g set: OFF
MODE ↓↑ = SCROLL ENTER**

6. Press the ENTER key. Press either ARROW key and the screen will display Base Tim'g set: ON.
7. Set the base timing using a timing light and engine running at 1500rpm. Turn the distributor until 10° advance is set.
8. Press the UP ARROW or DOWN ARROW key to turn Base Tim'g set to OFF.

WARNING: DO NOT DRIVE THE VEHICLE WITH THE BASE TIM'G SET ON. SERIOUS ENGINE DAMAGE MAY RESULT

NOTE: If you use an advance-type timing light, the degrees advance shown on the Calibration Module (SPRK:) should always agree with the actual reading at the crank with the timing light.

9. Press the MODE key. You can now leave this screen using the UP ARROW or DOWN ARROW keys.

Idle Adjustment

This procedure is a general recommendation, intended to help you fine tune your Pro-Flo® system.

NOTE: This procedure should be followed with the car in Neutral and the brake pedal pressed.

Idle Calibration Procedure

- Prior to idle calibration, you need to have completed the "System Start-Up" procedure
- Warm up the engine to at least 175°F.
- Using the calibration module, Select MISC. MODIFIERS and Set Idle Control OFF.
- Check the idle speed, and adjust your throttle blades to achieve the desired speed, if necessary.
- Note the VAC value on the calibration module.
- Go to Fuel Modifiers and find the RPM and VAC setting closest to your current Idle RPM and VAC readings.
- Slowly add or subtract fuel until you get the best idle quality.
- Readjust the idle speed with the blade adjustment screw until the desired idle RPM is achieved.
- Note the VAC value on the calibration module once again.
- Go to Spark Modifiers and find the RPM and VAC settings closest to your current Idle RPM and VAC readings.
- Slowly add or subtract spark until you get the best idle quality.
- Readjust the idle speed with the blade adjustment screw to desired idle speed, if necessary.
- Turn Idle Control back on. There should be very little, if any, change to the idle speed with Idle Control ON or OFF at idle, in neutral.
- Save changes to Position A in the calibration module.

NOTE: You must save your changes before turning the ignition ON/OFF. If they are not saved, they will be erased when you restart.

Idle Troubleshooting

Vehicles equipped with an automatic transmission should now be able to shift into Drive, with the brake still depressed, and see a slight dip in engine rpm followed by a resumption of the idle speed set in the procedure above. If any surging or an erratic idle occurs, follow the steps below:

- Note the lowest RPM during the surging and the average VAC readings.
- Shift the transmission into neutral.
- Use the Calibration Module to turn off Closed Loop Control.
- Go into the Fuel Modifiers and find the RPM and VAC settings closest to the values noted above.
- Add 5% fuel.
- Put the transmission back into Drive and see if the surging has gotten better or worse.
- Go back and add or subtract fuel until you get the highest VAC and a stable idle.
- When you are satisfied with the results, turn closed loop back ON and save changes to position A again.

Idle Tuning Tips

- The ECU always starts in position A. you must save the changes to position A for them to do anything. You can save your current tune into B or C and restore them if you want. They will restore to A.
- You should never have big jumps in the Fuel or Spark modifiers from one location to the next. If you have 10% in one location the surrounding locations should not vary more than an additional 10%.
- Only use the Idle fuel and spark settings once you have the regular Fuel and Spark Modifiers where the engine runs the best.
- Closed loop control does not work at Idle.

Save Calibration

- Using the calibration module, Select MISC. MODIFIERS
- Set IDLE CONTROL ON. Set TARGET IDLE to the same RPM established by the idle stop screw.
- Save calibration settings to "A"

ELECTRONIC ENGINE MANAGEMENT

The Edelbrock Pro-Flo system uses the Speed-Density method of electronic engine management, in which fuel and spark requirements are based on engine speed (RPM) and engine load (manifold pressure and temperature).

The Electronic Control Unit (ECU) receives signals regarding engine speed (from the distributor), and the three load factors consisting of coolant temperature (ECT), Manifold Absolute Pressure (MAP) and air temperature (MAT). Once the ECU has determined the engine operating point (RPM and Load factor), it uses tables programmed into it to instantly calculate correct spark advance and injector pulse width.

The Pro-Flo system displays vacuum rather than the less-familiar manifold pressure. This vacuum reading is based on the following SAE standard atmosphere:

Barometer 29.5 in Hg
 Temperature 77°F

Because of this, the vacuum figures displayed on the Calibration Module may differ from the vacuum indicated by a true vacuum gauge, particularly at extreme high or low altitude.

FUEL MODIFIER TABLE

FUEL MODIFIER TABLE

		RPM					
		1000	2000	3000	4000	5000	7000
LOAD	WOT						
	6"						
	12"						
	18"						

SPARK MODIFIER TABLE

SPARK MODIFIER TABLE

		RPM					
		1000	1750	2500	3500	4500	6000
LOAD	WOT						
	9"						
	18"						

The Calibration Module allows you to modify the fuel and spark tables at various engine speeds and levels of vacuum. These tables may be used for recording your modifications to the base table with your own fuel pulse width and spark advance figures.

PRO-FLO QUICK TUNING GUIDE

This guide is based on our simple graph that shows the 24 fuel cells that you can tune in to result in a clean and powerful engine. We recommend when you have your Pro-Flo installed, you have the idle tune up completed and then drive the vehicle to determine what amount of fuel is needed for general driving. If the unit is driveable, this is the method to use for ease of tuning. On page 31 of this installation manual, there is a fuel grid that can be used as the map on which to locate and then tune any drivability problems. Simply drive the vehicle and note any areas that have problems. Circle those areas as a baseline.

When circling the area where a problem exists, you are circling the RPM and Vacuum reading that is present when the problem occurs. Note whether it is running rich (green light) or lean (red light) at each problem area. Once any problem areas have been located and noted rich or lean, go into the Miscellaneous Modifiers menu and turn off the Closed Loop Fuel, exit, go to Fuel Modifiers, and then into Global Fuel. Now drive the vehicle and drive back to each problem area. When driving in a problem area, add or subtract fuel to obtain the smoothest operation at that driving point. Write down the quantity (plus or minus) of fuel required to achieve a smooth operation. When all the problem areas have been noted, and the amount of fuel required to achieve smooth operation has been noted at each problem area, you may now do each adjustment one at a time to achieve a complete tune up.

To input this information, you will need to make sure the Closed Loop Fuel is in the OFF position. Go to each area and enter the information. If you have found a problem that is not exactly in the center of one of the fuel cells, you will still be able to tune the area by using the Surround and Conquer method for properly managing the fuel curve. Listed below is an example of this method:

Assume that you have found a problem area at 2500 RPM and 15 inches of Vacuum. This is not an area where you can address the problem directly. In this scenario, we will say the unit is showing a lean condition (red light). In which case, fuel will need to be added. We will also say that when driving and using the Global Modifier to find the exact amount of fuel required, it was determined that the amount needed was plus ten percent (+10%). In the Surround and Conquer method, you will add fuel at the four locations surrounding the problem area. This is shown in the figure below:

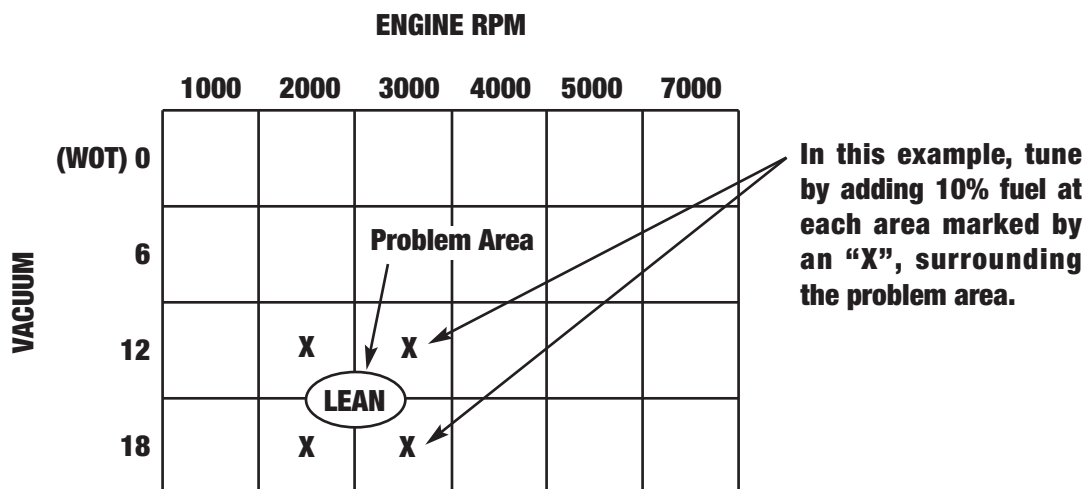

When the required amount of fuel has been added at each surrounding fuel cell, complete the operation by returning to the Miscellaneous Modifiers menus, and turning the Closed Loop Fuel ON. Press the SAVE key, then the ENTER key. The hand-held unit will show SAVING IN PROGRESS. Repeat this procedure at each problem area to complete the tune up.

OPTIONAL PC TUNING FEATURE

To use the optional PC tuning feature, connect a DB9 serial extension cable to connector J25 of the main harness. Connect the other end to your PC's serial port as shown. Double click on the bEditor icon shown below.

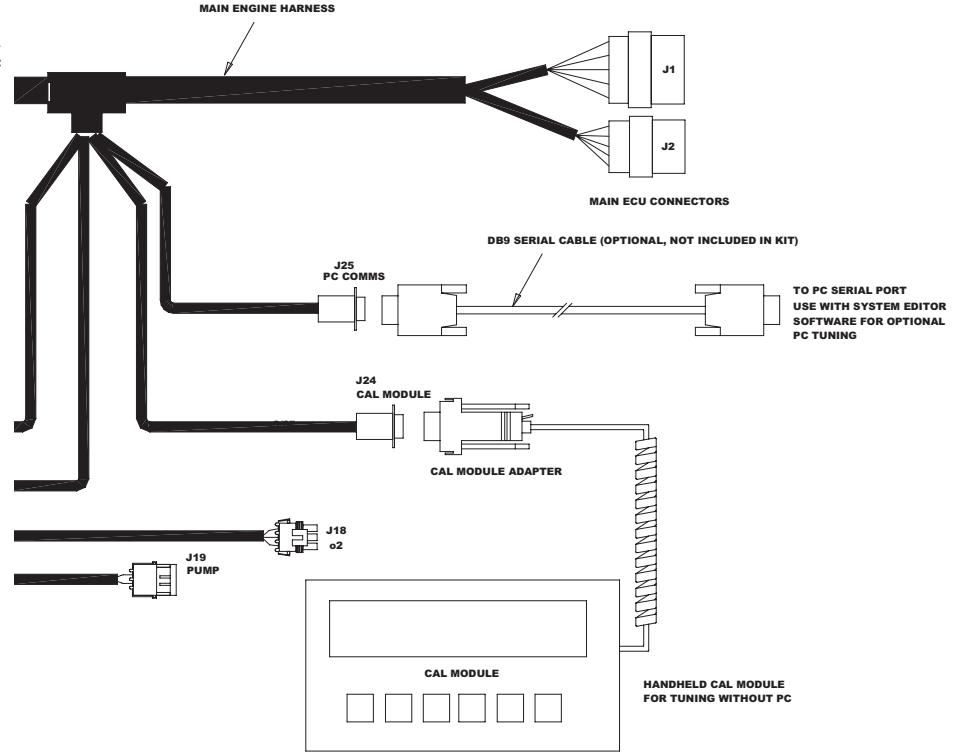

The engine controllers included in the Edelbrock Pro Flo system CANNOT be edited live using the bEditor software. In other words, bEditor can only be used to edit the calibration file loaded in the software. You cannot directly edit the calibration file loaded into the ECU. When you make changes to a calibration file, it must be saved and flashed into your ECU's memory before those changes take effect. For additional information on using bEditor to edit your calibration files, refer to the online help by selecting the Help menu at the top of the screen.

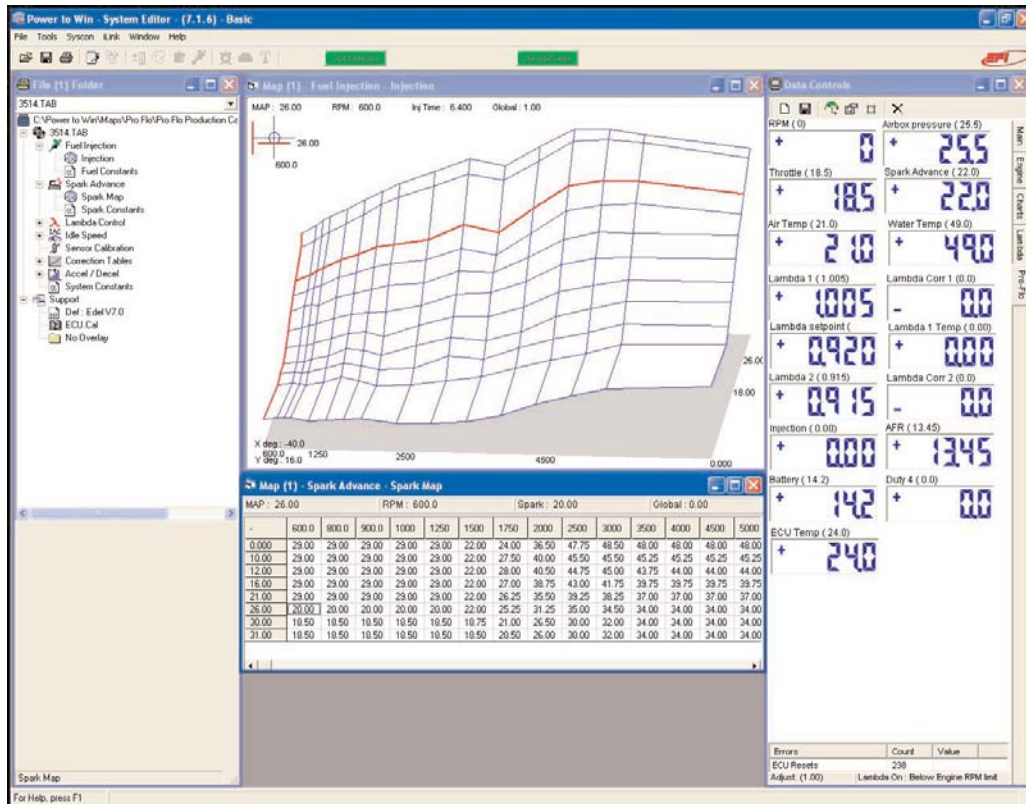

CALIBRATION MODULE FLOWCHART

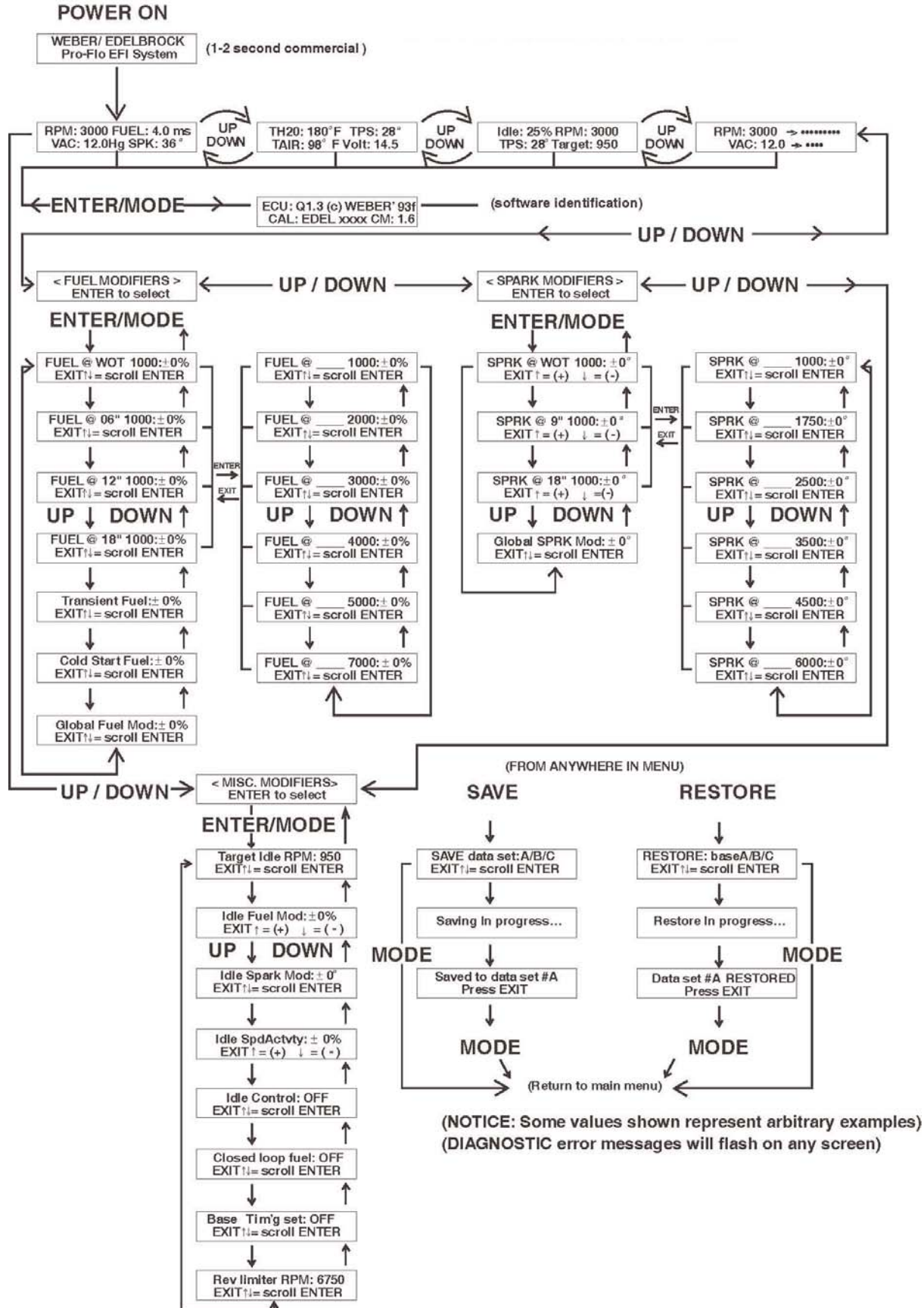

PART NUMBERS

Many of the components of the Pro-Flo system are available separately. Many are standard OEM parts. In the event that one of these parts need to be replaced, you are likely to find a replacement at your local parts supplier, in addition to your local Edelbrock dealer or directly from Edelbrock.

Edelbrock Pro-Flo

Fuel Injection System.....	Edelbrock #35500, 35510
Manifold Absolute Pressure sensor	Edelbrock #36019
Manifold Air Temperature sensor (Push-In)	Edelbrock #3579 AC Delco #12160244
Coolant Temperature sensor	Edelbrock #3589 GM #25036979
Throttle Position sensor	Edelbrock #3590
Oxygen (O ₂) sensor	Edelbrock #36013
High pressure fuel pump.....	Edelbrock #3594
Fuel filter	Edelbrock #3596 GM #25055065
Fuel pressure regulator.....	Edelbrock #3584 GM #17107010
Fuel injectors (set of eight).....	
#3550 Kit use	Edelbrock #3684
#3551 Kit use	Edelbrock #3598
Fuel injectors (one).....	
#3550 Kit use	Edelbrock #3685
#3551 Kits use	Edelbrock #3585
Hall Effect Sensor	Edelbrock #3517
Idle air control solenoid.....	Edelbrock #3599 Ford FOAE-9F715 B1A
Throttle Cable Bracket #3550 or #3551	Edelbrock #8031

SERVICE

In the event that your Edelbrock Pro-Flo System should need servicing, return the unit pre-paid to the Edelbrock Service and Repair facility at 2700 California Street, Torrance, CA 90503. Do not attempt to disassemble or service the components of the Pro-Flo system yourself. Doing so may void the warranty.

WARRANTY

It is the constant endeavor of the Edelbrock Corp. to provide our customers with the highest quality performance products. Edelbrock warrants the Edelbrock Pro-Flo System to be free from defects in both workmanship and materials for a period of one year from date of purchase, provided that the product is properly installed and subjected to normal use and service, is not used for racing or competition purposes and that the product is not modified or altered in any way unless specified by our instructions. Our warranty service and repair facility is located at 2700 California Street, Torrance, CA 90503. Customers requiring warranty assistance should contact the dealer from whom they purchased the product. In turn, the dealer will contact Edelbrock, and we will determine the method of satisfying the warranty. Should Edelbrock determine that the product be returned to the factory, it should be accompanied by proof of purchase and a clear description of the exact problem. The product must be returned freight pre-paid. If a thorough inspection of the product by the factory indicates defects in workmanship or material, our sole obligation shall be to repair or replace the product. This warranty covers only the product itself and not the cost of installation or removal.

EDELBRICK CORP. SHALL NOT BE LIABLE FOR ANY AND ALL CONSEQUENTIAL DAMAGES OCCASIONED BY THE BREACH OF ANY WRITTEN OR IMPLIED WARRANTY PERTAINING TO THIS SALE, IN EXCESS OF THE PURCHASE PRICE OF THE PRODUCT SOLD.

If you have any questions regarding this product or installation, please contact our Technical Department from 7:00am - 5:00pm, Pacific Standard Time, Monday through Friday at:

Tech Telephone: (800) 416-8628
Sales Telephone: (310) 781-2222
Fax: (310) 972-2730

Edelbrock Corporation
2700 California Street
Torrance, CA 90503





Tech Telephone: (800) 416-8628
Tech Hours: 7am-5pm PST, Weekdays
Office Telephone: (310) 781-2222
E-Mail: efitech@edelbrock.com
Tech Fax: (310) 972-2730

Edelbrock Corp.
2700 California Street
Torrance, CA 90503