



EDELBROCK VICTOR SERIES DRAG RACE HEADERS
for 1996-2002 4.6L Ford Mustang
Catalog #6560
KIT CONTENTS

| Qty. | Part No. | Description | Qty. | Part No. | Description |
|------|----------|-------------------------------------|------|----------|--|
| 1 | 25-9219 | Left Side Header Primaries #1 & #2 | 16 | 68-0350 | 8mm x 1.25 x 30mm Hex Bolts (Header Flange) |
| 1 | 25-9220 | Right Side Header Primaries #3 & #4 | 4 | 68-6550 | 5/16" - 18 x 1-1/2" Grade 8 Hex Bolt (Collector) |
| 2 | 25-9221 | Slip On Merge Collector | 2 | 79-9749 | Evacuation Tubes |
| 1 | 25-9361 | Right Header Primary #1 | 8 | 79-9750 | Collector Mounting Tabs |
| 1 | 25-9362 | Right Header Primaries #2, #3, & #4 | 8 | 82-3600 | 5/16" AN Washers (Collector) |
| 2 | 37-6560 | O2 Sensor Wire Extensions | 20 | 82-4620 | 5/16" Split Lock Washers (Header Flange) |
| 2 | 52-9710 | O2 Sensor Bungs | 16 | 82-8721 | 5/16 Hardened Washers (Port Flange) |
| 2 | 54-0426 | Header Port Flange Gaskets | | | |
| 4 | 60-8541 | 5/16"-18 Hex Nuts (Grade C Lock) | | | |

Note: Your Edelbrock Victor Series Race Headers include evacuation tubes, O2 sensor bungs, and collector mounting tabs, to be installed, if needed or required. This allows you to custom-tailor the header for a better fit and finish for your particular needs and class requirements.

1. Evacuation tubes (if used) can be positioned in the collector where desired for best fit and routing of the hoses (route hoses away from hot engine components). See diagram for recommended positioning of evacuation tube.
2. Collector mounting tabs should be installed after primary tube tuning has been completed (if applicable).
3. O2 sensor bungs (if used) can be positioned on the header collector where the sensor wires can be routed away from hot engine components (O2 sensor wire extensions are provided). Drill 3/4" hole and weld bung to collector.

Special Components that may be needed, if applicable:

Note: Oxygen Sensor Simulators may be purchased from the following: SLP PT #31036; Phone (732) 349-2109; Mid America Designs, Inc. PT #609132, Phone (217) 347-5591; RPM Outlet, Phone (713) 858-8095.

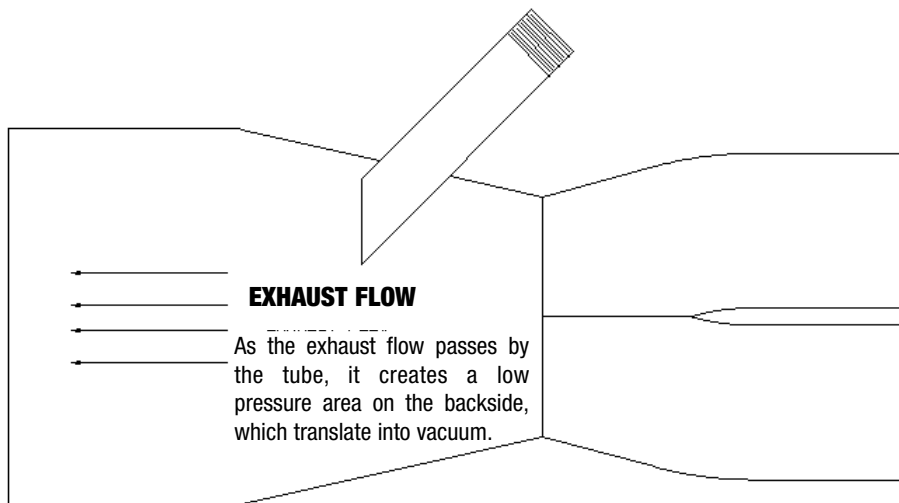

Edelbrock Corporation, 2700 California St., Torrance, CA 90503
Tech Line: 1-800-416-8628; Office: 310-781-2222
E-Mail: Edelbrock@Edelbrock.com