

REVISIONS			
LTR	DESCRIPTION	DATE	APPROVED
	INITIAL RELEASE	08/09/06	

PN 301308

IGNITION ADAPTER - FORD TFI

TO "CAM/HALL EFFECT"
CONNECTOR ON XFI
MAIN HARNESS

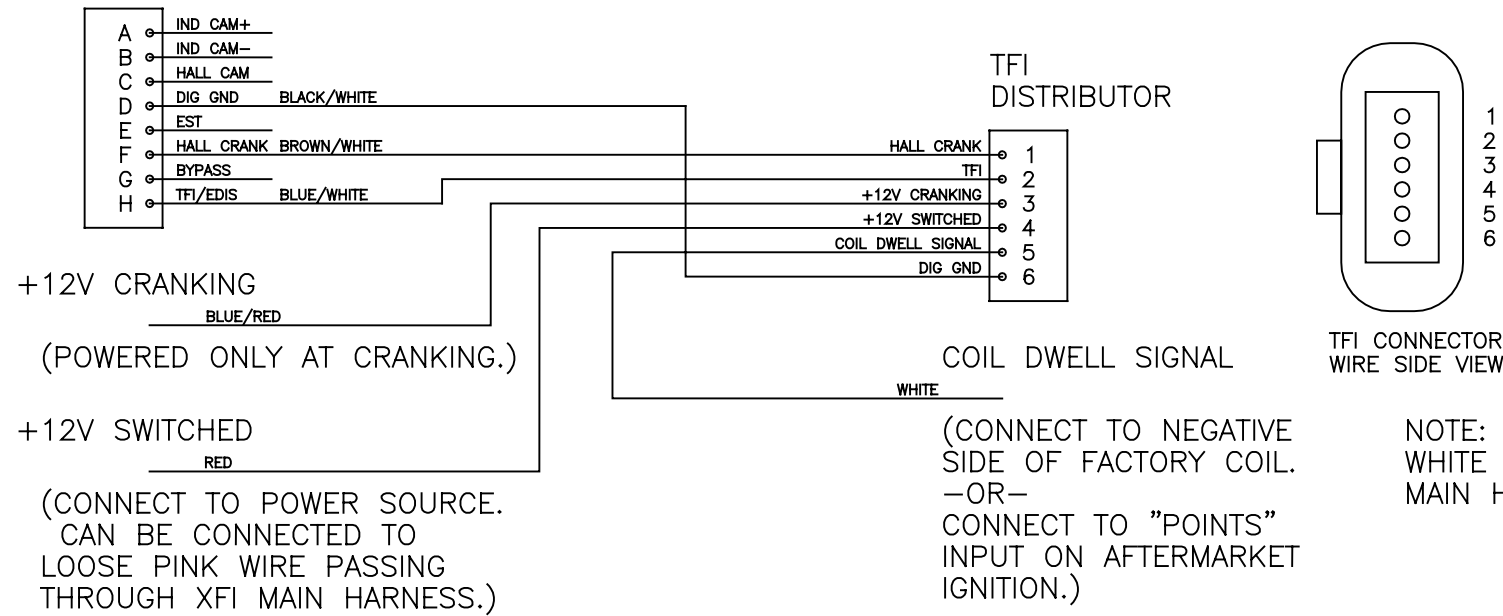

PN 3013xx (NOT OFFERED PRE-ASSEMBLED)

IGNITION ADAPTER - FORD EDIS (8 CYLINDER)

TO "CAM/HALL EFFECT"
CONNECTOR ON XFI
MAIN HARNESS

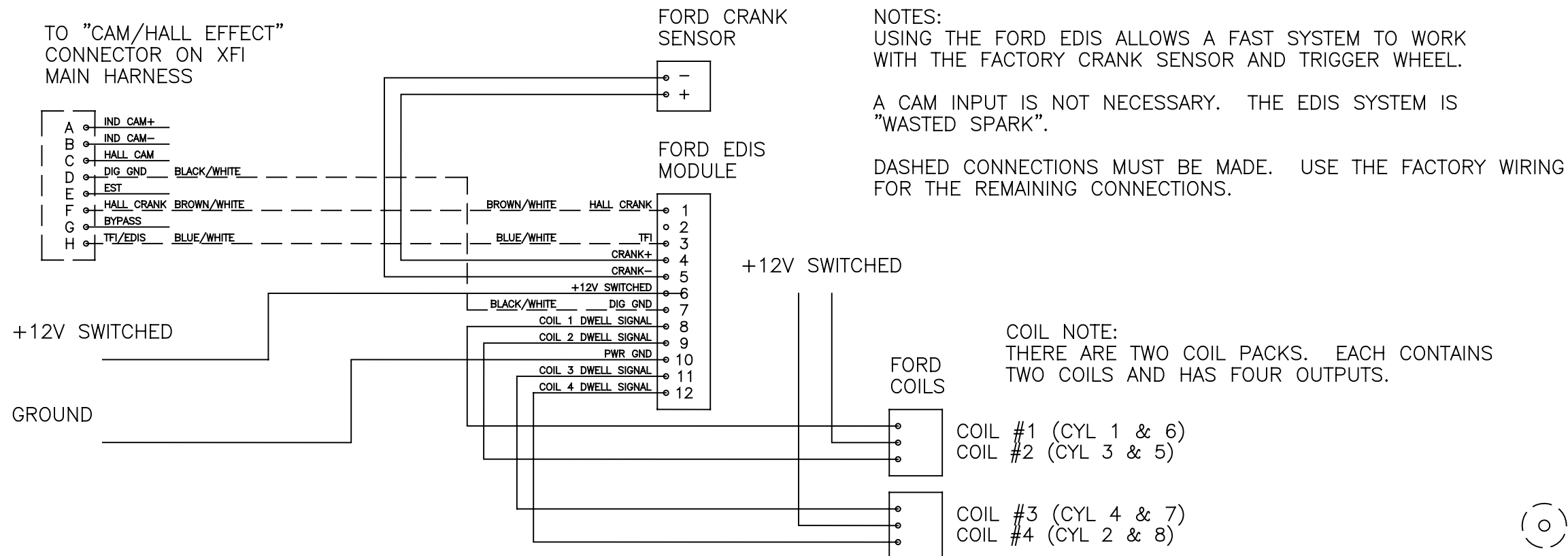

	FAST XFI IGN. ADAPTERS FORD TFI & FORD EDIS PN 301308 & 3013xx	
	DRAWN BY : RLW	DATE : 08/09/06
REV : ...	DRAWING NO : 301308-xx SCHEMATICS	
...	SHEET NO : 1 OF 1	

⊙
DENOTES SPLICE