

REVISION HISTORY

REV	DESCRIPTION	DATE	NAME
A00	Initial Design	3/1/07	RJT

STEP #1

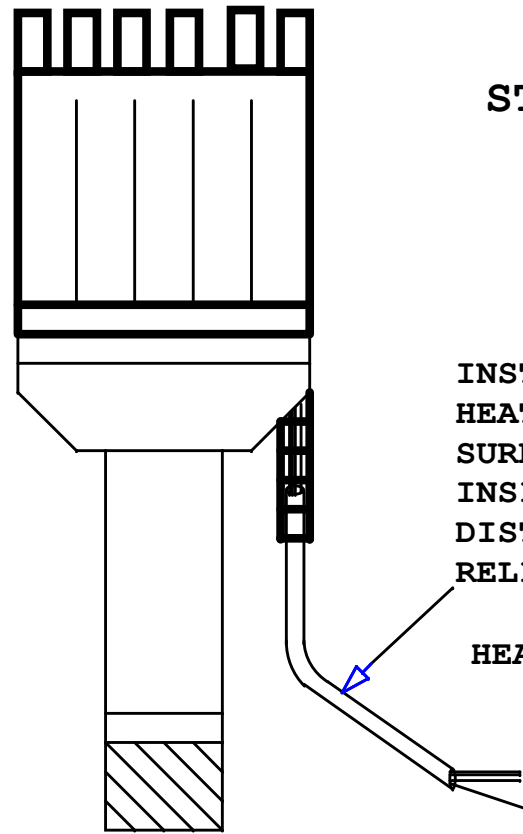

INSTALL 16" OF HEATSHRINK. MAKE SURE TO SLIDE IT INSIDE THE DISTRIBUTOR'S STRAIN RELIEF.

HEATSHRINK: 170049

STEP #2

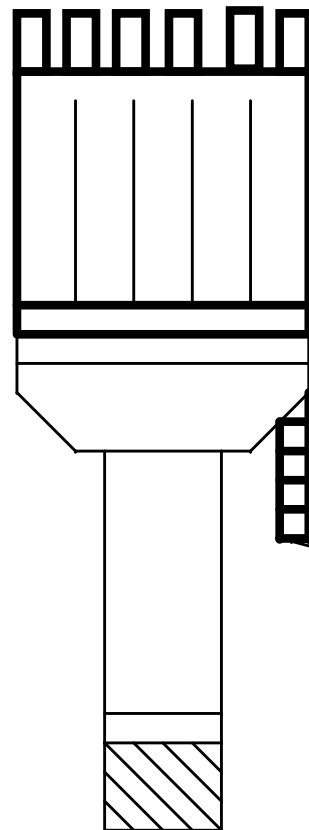

USE BLUE HANDLE WIRE CRIMPERS TO CRIMP PINS

- (1) CONNECTOR: 170264
- (5) RUST SEALS: 170087
- (1) LOCK: 170213
- (3) TERMIAL: 170557
- (3) BLUE SEALS: 170558

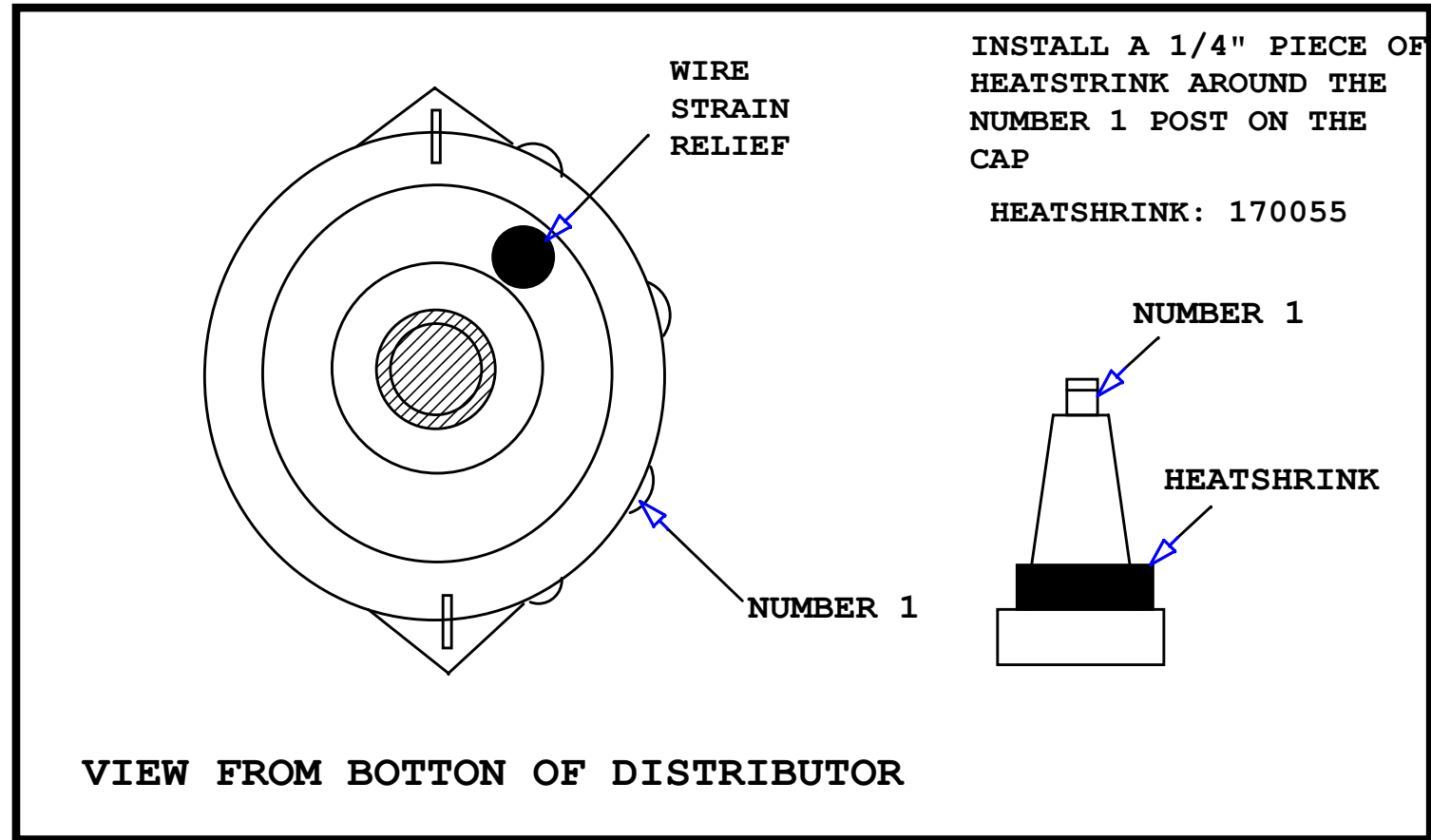
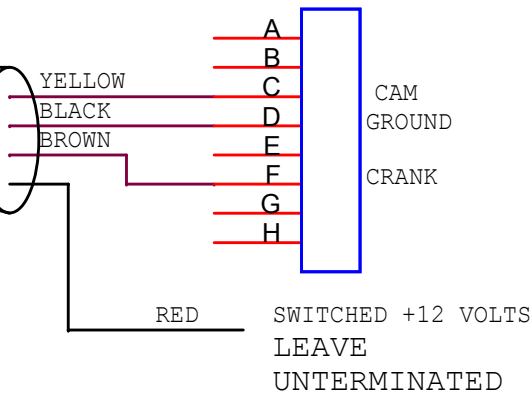

VIEW FROM BOTTON OF DISTRIBUTOR

FAST
FUEL AIR SPARK TECHNOLOGY

3753 Old US23, Suite 300, Brighton, MI 48114

Title
OLDS Distributor Connector Installation

Size A	Document Number 305018	Rev A00
-----------	---------------------------	------------

Date: Tuesday, April 06, 2010 Sheet 1 of 1